

## Dew Point Analyser

Model 1638



August 2007



## CONTENTS

1. SPECIFICATIONS
2. DESCRIPTION
3. INSTALLATION & COMMISSIONING
4. OPERATORS FUNCTIONS - ALARMS
5. SETTING UP THE ANALYSER
6. MAINTENANCE

### **APPENDIX**

1. PROBE EMF TABLES
2. LOG OXYGEN SCALE
3. SAMPLE LOG PRINT OUT
4. CIRCUIT SCHEMATIC
5. MODBUS™ REGISTER MAP AND APPLICATION NOTES

**Note: This manual includes software modifications up to Version 8.11, May, 2006**

**© Copyright NOVATECH CONTROLS PTY. LTD. - 1996 - 2007**

This manual is part of the product sold by Novatech Controls Pty. Ltd. ("Novatech Controls") and is provided to the customer subject to Novatech Controls' conditions of sale, a copy of which is set out herein. Novatech Controls' liability for the product including the contents of this manual is as set out in the conditions of sale.

All maintenance and service of the product should be carried out by Novatech Controls' authorised dealers.

This manual is intended only to assist the reader in the use of the products. This manual is provided in good faith but Novatech Controls does not warrant or represent that the contents of this manual are correct or accurate. It is the responsibility of the owner of the product to ensure users take care in familiarising themselves in the use, operation and performance of the product.

The product, including this manual and products for use with it, are subject to continuous developments and improvement by Novatech Controls. All information of a technical nature and particulars of the product and its use (including the information in this manual) may be changed by Novatech Controls at any time without notice and without incurring any obligation. A list of details of any amendments or revisions to this manual can be obtained upon request from Novatech Controls. Novatech Controls welcome comments and suggestions relating to the product including this manual.

Neither the whole nor any part of the information contained in, or the product described in, this manual may be adapted or reproduced in any material form except with the prior written approval of Novatech Controls Pty. Ltd.

All correspondence should be addressed to:

Technical Enquiry's  
Novatech Controls Pty Ltd  
309 Reserve Road  
Cheltenham Victoria 3192  
Australia

Phone: Melbourne +61 3 9585 2833  
Fax: Melbourne +61 3 9585 2844  
Email: [info@novatech.com.au](mailto:info@novatech.com.au)  
[www.novatech.com.au](http://www.novatech.com.au)

# USING THIS MANUAL

The Novatech 1638 Oxygen Transmitter has a variety of user-selectable functions.

They are simple to use because each selection is menu driven. For options you are not sure about; read the manual on that particular item.

Please read the safety information below and the 'Installation' section before connecting power to the analyser.

## CAUTION 1

The probe or sensor heater is supplied with mains voltage. This supply has electrical shock danger to maintenance personnel. Always isolate the analyser before working with the probe or sensor.

The EARTH wire (green) from a heated probe or sensor must ALWAYS be connected to earth.

## CAUTION 2

Combustion or atmosphere control systems can be dangerous. Burners must be mechanically set up so that in the worst case of equipment failure, the system cannot generate explosive atmospheres. This danger is normally avoided with flue gas trim systems by adjustment so that in the case of failure the appliance will not generate CO in excess of 400 ppm in the flue. The CO level in the flue should be measured with a separate CO instrument, normally an infrared or cell type.

## CAUTION 3

The oxygen sensor which is heated to over 700°C (1300°F) and is a source of ignition. Since raw fuel leaks can occur during burner shutdown, the analyser has an interlocking relay that removes power from the probe or sensor heater when the main fuel shut-off valve power is off. If this configuration does not suit or if it is possible for raw fuel to come into contact with a hot oxygen probe or sensor then the Model 1638 analyser with a heated probe or sensor will not be safe in your application.

An unheated probe can be utilised in such applications, however the oxygen readings are valid only above 650°C (1200°F).

# SPECIFICATIONS

# 1

- 1.1 MODEL 1638 OXYGEN ANALYSER FOR TWO OXYGEN SENSORS
- 1.2 SERIES 1230 OXYGEN PROBES AND SENSORS
- 1.3 PURGE & CALIBRATION CHECK ACCESSORIES
- 1.4 FILTER PURGE SWITCH

## 1.1 Model 1638 Oxygen & Dew point Analyser

### DESCRIPTION

The Novatech model 1638 oxygen analyser / transmitter provides in-situ measurement for one or two oxygen probes in annealing and other furnaces with protective atmospheres of hydrogen / nitrogen. The analyser provides local indication of oxygen and dew point plus sixteen other selectable variables.

One or two oxygen sensing probes in one process can be controlled from one analyser to providing an average and/or individual probe signals. Two linearised and isolated 4 to 20 mA output signals are provided for oxygen and for dew point. Alarms are displayed at the analyser and relay contacts activate remote alarm devices. The analyser, which is available for heated or unheated zirconia oxygen probes, provides automatic on-line gas calibration check of the probe and filter purging. The electronics self-calibrates all inputs every minute.

The 1638 has a keyboard for selecting the output range, thermocouple type, etc., as well as maintenance and commissioning functions. The instrument is microprocessor based and all adjustments are made using the keyboard.

- Used for product quality control to avoid blueing or browning of steel products during the annealing process
- Used for monitoring hydrogen / nitrogen protective atmospheres in applications such as lead holding furnaces
- Automatic selection of second probe on probe failure
- Simple to install
- Linear output of % oxygen and dew point for recording or control
- Built in safety features
- 24 different alarm conditions that warn the operator of oxygen, dew point, probe or analyser problems
- Isolated RS 232-C printer/computer interface and an RS 485 MODBUS network interface
- Safety interlock relay for heated oxygen probes

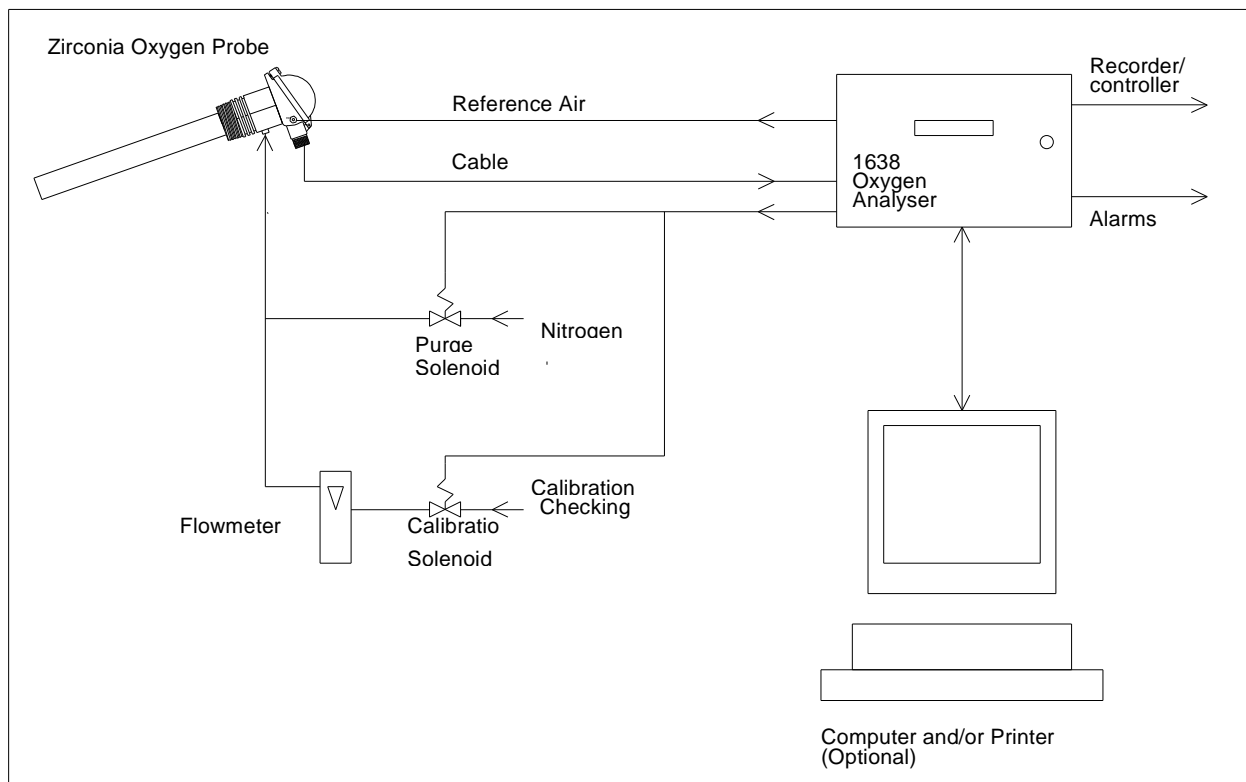

Oxygen Probe and Analyser System

## SPECIFICATIONS

### Inputs

- Zirconia oxygen probe, heated or unheated
- Furnace thermocouple, field selectable as type K or R
- Process purge complete / main flame established safety interlock (for heated probes)
- Purge pressure switch
- Remote alarm accept

### Outputs

- Two linearised 4 to 20 mA DC outputs, max. load 1000Ω
- Common alarm relay
- Three other alarm relays with selectable functions

### Computer

- RS 232-C or RS 485 for connection of a computer terminal or printer for diagnostics of the analyser, sensing probe, or process. This connection is suitable for network connection to computers, DCSs or PLCs using MODBUS protocol.

### Range of Output 1

Field selectable from the following:

<i>Output</i>	<i>Zero Range</i>	<i>Span Range</i>
Dew point	-60°C to +20°C -76°F to +84°F	-40°C to +40°C -56°F to +104°F
Linear oxygen	0 to 99 %	1 to 100 %
Oxygen, reducing range	1.0 <sup>-16</sup> % oxygen	1.0 <sup>-30</sup> % oxygen

*If 2 probes are used -*

Linear oxygen, probe 1	0 to 99 %	1 to 100 %
Reducing oxygen output probe 1	1.0 <sup>-16</sup> % oxygen	1.0 <sup>-30</sup> % oxygen
Dew point, probe 1	-60°C to +20°C -76°F to +84°F	-40°C to +40°C -56°F to +104°F
Linear O <sub>2</sub> , probe 1 & 2 averaged	0 to 99 %	1 to 100 %
Reducing O <sub>2</sub> , probe 1 & 2 averaged	1.0 <sup>-16</sup> % oxygen	1.0 <sup>-30</sup> % oxygen
Dew point, probe 1 & 2 averaged	-60°C to +20°C -76°F to +84°F	-40°C to +40°C -56°F to +104°F

Note:

The average dew point, linear O<sub>2</sub> and Reducing O<sub>2</sub> selections will automatically select to the operating probe if one probe fails, or selects probe 1 if both probes fail.

### Range of Output 2

Field selectable from the following:

<i>Output</i>	<i>Zero Range</i>	<i>Span Range</i>
Linear O <sub>2</sub>	0 to 99 %	1 to 100 %
Oxygen, reducing range	1.0 <sup>-16</sup> % oxygen	1.0 <sup>-30</sup> % oxygen
Dew point	-60°C to +20°C -76°F to +68°F	-40°C to +40°C -40°F to +104°F
Sensor EMF	0 to 1200 mV in 100 mV steps	100 to 1300 mV in 100 mV steps
Aux Temperature	0 to 1300°C in 100°C steps	100 to 1400°C in 100°C steps

*If 2 probes are used -*

Linear O <sub>2</sub> , probe 2	0 to 99 %	1 to 100 %
Oxygen, reducing range, probe 2	1.0 <sup>-16</sup> % oxygen	1.0 <sup>-30</sup> % oxygen
Dew point, probe 2	-60°C to +20°C -76°F to +68°F	-40°C to +40°C -40°F to +104°F
Probe EMF 1	0 to 1200 mV in 100 mV steps	100 to 1300 mV in 100 mV steps
Probe EMF 2	0 to 1200 mV in 100 mV steps	100 to 1300 mV in 100 mV steps

#### Range of Indication, Upper Line

- Oxygen auto ranging from 10<sup>-30</sup> to 100 %
- Dew point -60 °C to +40 °C, -76 °F to +104 °F

#### Indication Choice, Lower Line

Any or all of the following can be selected for lower line display:

- Dew point probe 1
- Dew point probe 2 \*\*
- Dew point probe 1 and 2 averaged \*\*
- Date - time
- Run Hours since last service
- Date of last service
- Oxygen probe 2 \*\*
- Oxygen probe 1 and 2 averaged \*\*
- Probe EMF 1
- Probe EMF 2 \*\*
- Temperature probe 1
- Auxiliary Temperature \*
- Temperature probe 2 \*\*
- Impedance probe 1
- Impedance probe 2 \*\*
- Ambient Temperature
- Ambient Relative Humidity

\* If the analyser is enabled for 1 probe

\*\* If the analyser is enabled for 2 probes

#### Accuracy

- ±1% of actual measured oxygen value with a repeatability of ±0.5% of measured value.

#### Relay Contacts

- 0.5A 24 VAC, 1A 36 VDC

#### Environmental Rating

- Operating Temperature: -25 to 55°C
- Relative Humidity: 5 to 95% (non-condensing)
- Vibration: 10 to 150Hz (2g peak)

#### Power Requirements

- 240 or 110V, 50/60 Hz, 105 VA (heated probe)
- 240 or 110V, 50/60 Hz, 5 VA (unheated probe)

#### Weight

- Analyser, 3.75 kg

#### Degree of Protection

- IP65 without reference air pump
- IP54 with reference air pump

#### Mounting

- Suitable for wall or surface mounting.

## 1.2 Series 1230 Oxygen Probes

### DESCRIPTION

Novatech series 1230 oxygen probes employ state-of-the-art zirconia sensors and advanced materials, which provide the following benefits:

- Improved control due to fast response time to typically less than four seconds
- Cost-efficient design provides improved reliability
- Longer-life probe to greater resistance to corrosion from sulphur and zinc contaminants in some furnaces
- Reduced probe breakage due to greater resistance to thermal shock and mechanical damage during installation and start-up

Series 1230 probes are simple to install and maintain. All models provide a direct measurement of oxygen levels. On-line automatic calibration check is available if required.

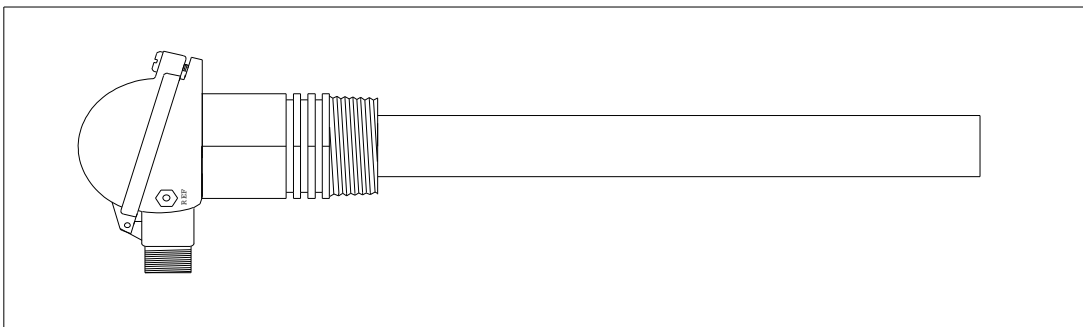

**Model 1231 Heated Oxygen Probe**

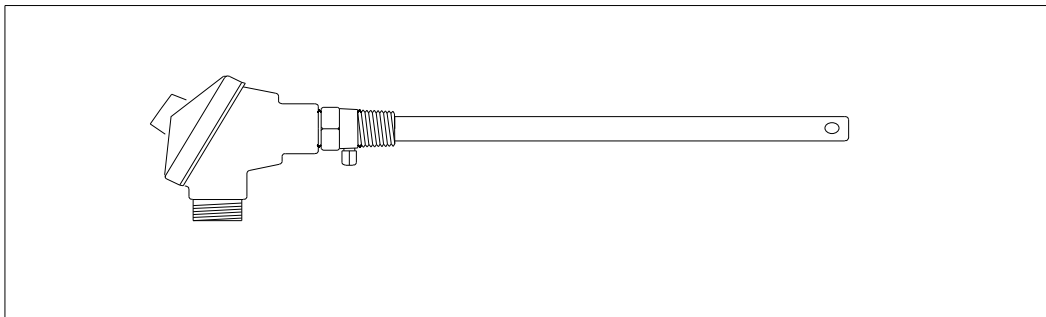

**Model 1232 Unheated Oxygen Probe**

### STANDARD PROBE 'U' LENGTHS

<b>1231</b>	<b>1232</b>
250 mm	250 mm
350 mm	500 mm
500 mm	750 mm
750 mm	1000 mm
1000 mm	1500 mm
1500 mm	
2000mm	

#### Ordering Information

1. Probe insertion length (from process end of mounting thread to probe sensing tip).
2. Mounting thread (process connection), BSP or NPT (for size of thread refer to specifications).
3. Lagging extension length, if required.
4. If model 1232 probe, state preferred thermocouple type (refer to specifications).

## OXYGEN PROBE SPECIFICATIONS

<b>MODEL</b>	<b>1231</b>	<b>1232</b>
<b>Application</b>	Furnaces operating below 900°C refer to note 1	Furnaces operating above 700°C with no contaminants.
<b>Temperature Range</b>	0 to 900°C (0 to 500°C with filter fitted)	700 to 1400°C
<b>Length</b>	250 to 2000 mm	500 to 1000 mm
<b>Process Connection</b>	1 1/2" BSP or NPT	3/4" BSP or NT
<b>Electrical Connection</b>	Weather-proof plug-in connector or optional screw terminals. The plug connector is supplied with the cable. Ex(e) heads have screw terminals.	
<b>Cable</b>	Order a specific length with the analyser except for hazardous installations where the cable is supplied by the customer.	
<b>Heater</b>	Yes	No
<b>Furnace Thermocouple</b>	Refer to note 3	R or S, integral
<b>Response Time</b>	Typically < 4 secs.	Typically < 1 sec
<b>Head Temperature</b>	-25 to 100°C with weatherproof connector -25 to 150°C with screw terminals	
<b>Reference Gas</b>	Ambient air 50 cc/min approx. Pump supplied with analyser	
<b>Ref Air Connection</b>	1/4" Tube	Integral air line in probe cable or external 1/4" tube.
<b>Optional Filter</b>	Sintered titanium alloy particulate filter, replaceable, 30 or 15 micron.	
<b>Calibration Check Gas Connection</b>	1/8" NPT female	1/8" NPT female
<b>Weight</b>	2 kg plus 165 g / 100 mm	1 kg plus 100 g / 100 mm

**Notes:**

1. Care must be taken to avoid contact with explosive or inflammable gases with 1231 heated probes. Novatech analysers have built in safety protection.
2. Please contact factory for corrosives other than sulphur or zinc. We can provide test materials to try in your atmosphere.

## OXYGEN PROBE MODEL SELECTION GUIDE

### *Heated probes-temperature range 0-900°C.*

<b>1231</b>	-	<b>U Length</b>	-	<b>Outer Sheath</b>	-	<b>Internal Thermocouple</b>	-	<b>Mounting Thread</b>
Basic model		2. 250mm 3. 500mm 4. 750mm 5. 1000mm 6. 1500mm 7. 2000mm		1. 316 SS max 850°C 2. Inconel *(1)		1. Type K max 900°C		1. BSP 2. NPT

\*Note:

1. The Inconel option has all inconel wetted parts except for the ceramic sensor and viton 'O' rings.

### *Unheated probes for clean gases-temperature range 700-1400°C.*

<b>1232</b>	-	<b>U Length</b>	-	<b>Outer Sheath</b>	-	<b>Internal Thermocouple</b>	-	<b>Mounting Thread</b>
Basic model		3. 500mm 4. 750mm 5. 1000mm 6. 1500mm		1. 253 MA-max 1200°C  3. High Purity Alumina max 1300°C Horizontal max 1400°C Vertical 4. 446 SS max 1000°C		1. Nil *(2) 4. Type R max 1400°C		1. 3/4" BSP fixed 2. 3/4" NPT fixed

\*Note:

1. For applications up to 1200°C it may be more economical to use a separate type "K" or "N" thermocouple than the internal "R" thermocouple. It is important that a separate thermocouple senses the same temperatures as the oxygen probe tip.

### 1.3 Purge & Calibration Check Accessories

Due to the absolute measurement characteristics of zirconia sensors and the self calibration features of Novatech analysers, probe calibration checks with calibrated gas are not normally required. In some installations however customers prefer the have a calibration check facility.

Novatech probes and analysers provide a ready method of connecting on-line calibration check gases. They provide on-line automatic checking of probe and analyser calibration, as well as a probe purge facility.

The absolute characteristics of zirconia sensors require only one calibration check gas to properly check the probe's performance. Where required however, the dual gas calibration check facility can be utilised.

Dirty furnace applications often require the back purge facility to keep a probe filter free from blockage. (In these applications, it is more reliable to install probes pointing vertically downwards with no filter). Purge and calibration check solenoid valves can be operated manually or automatically from a 1638 analyser.

The external components required for automatic / manual gas calibration checking are:

- A calibration check gas flow meter/regulator
- A mains voltage (240 or 110 VAC) solenoid valve for each calibration check gas

The external components required for automatic / manual purging are:

- A mains voltage (240 or 110 VAC) purge solenoid valve
- A purge pressure switch, 0 to 35 kPa (0 to 5 psi), to test for filter blockage.

The user should supply:

- Span gas cylinder(s), typically 2 % oxygen in nitrogen or a similar percentage of O<sub>2</sub> close to the normal level in the gas stream being measured, to ensure fast recovery.
- A 100 kPa (15 psi) clean and dry nitrogen supply when filter purging is required.

### 1.4 Filter Purge Pressure Switch

To automatically sense a blocked probe filter, a pressure sensor should be connected to the 'purge' line to the probe 'cal' port. It should be adjusted so that it energises just above the purge pressure with a new or clean filter installed. The switch contacts should be connected to terminals 12 & 13 (PURGE FL SWITCH). If the filter is still blocked or partly blocked after an auto purge cycle, the pressure switch will energise and cause a 'Probe Filter Blocked' alarm. The contacts must be normally closed.

The pressure switch should have an adjustable range of 0 to 35 kPa (0 to 5 psi).

# DESCRIPTION

## 2

### SECTION NUMBER

- 2.1 THE ANNEALING PROCESS
- 2.2 THE OBJECTIVE OF ATMOSPHERE MONITORING
- 2.3 WHAT DO WE NEED TO MEASURE?
- 2.4 ZIRCONIA OXYGEN PROBE MEASUREMENT
- 2.5 OTHER TYPES OF OXYGEN MEASUREMENT
- 2.6 DEW POINT MEASUREMENT
- 2.7 IN-SITU OXYGEN PROBES
- 2.8 THE ZIRCONIA SENSOR
- 2.9 THE ANALYSER
- 2.10 ALARMS
- 2.11 HEATER
- 2.12 APPLICATIONS WHERE SENSING POINT  
IS NOT AT ATMOSPHERIC PRESSURE
- 2.13 PROBE IMPEDANCE
- 2.14 AUTO CALIBRATION—ELECTRONICS
- 2.15 AUTO CALIBRATION CHECKING—PROBES
- 2.16 AUTO PURGE
- 2.17 RS 485 AND 232-C PORT
- 2.18 AUXILIARY TEMPERATURE THERMOCOUPLE
- 2.19 WATCHDOG TIMER
- 2.20 BACK UP BATTERY

## DESCRIPTION

### 2.1 The Annealing Process (or other similar applications)

The annealing process is carried out in an atmosphere of hydrogen and nitrogen to protect the surface of the steel from oxidising and discolouring during the annealing process. There is usually some air leakage in a furnace and the hydrogen serves to “mop up” the oxygen by combining with it to form water vapour.

### 2.2 The Objective of Atmosphere Monitoring

The primary objective of monitoring the furnace atmosphere is to be able to measure whether the steel product in the furnace will become oxidised during the process and to raise an alarm to warn the operator that there is a problem.

### 2.3 What Do We Need to Measure?

The variable that we need to measure to monitor the atmosphere to prevent oxidation of the product is the oxygen partial pressure at the surface of the steel. At any particular furnace temperature, there is a unique oxygen partial pressure, above which the steel will tend to oxidise and below which no oxidation will occur. The steel acts as a catalyst in the hydrogen / nitrogen bringing the gas at the surface close to chemical equilibrium. The composition of the gas at the surface is normally different from that of the gas nearby. For example, trace oxygen is quickly converted to water vapour.

In the gas, a reaction to form water vapour requires collisions involving two hydrogen molecules and one oxygen molecule, the probability of which is low. On the surface of the steel, one or the other of the molecules becomes partly immobilised. This increases the probability of successful collisions to form water vapour. Essentially, gas molecules are held on the steel surface, waiting for the complementary molecule(s) to arrive.

### 2.4 Zirconia Oxygen Probe Measurement

The catalytic process which occurs on the surface of the steel also occurs on a zirconia oxygen sensor. This means that the measurement of the oxygen level with a zirconia oxygen sensor exactly duplicates the equilibrium conditions of the gas at the surface of the steel. It measures the oxidation potential of the gas or its potential to damage or discolour the steel.

### 2.5 Other Types of Oxygen Measurement

Other types of oxygen analysers such as a paramagnetic analyser measure the unreacted molecular level of oxygen in the furnace atmosphere, which has no direct thermodynamic relationship with the effect of the gas on the steel. These analysers are not useful for measuring the oxidation potential in annealing furnace atmospheres.

### 2.6 Dew Point Measurement

Dew point measurement was commonly used in the past because dew point analysers were the only technology available at the time. Dew point can be related to the oxidation potential of the furnace atmosphere but the relationship depends on how much hydrogen is available at the surface of the steel. With dew point held constant, if the hydrogen level varies, so will the oxidation potential of the atmosphere. Dew point measurement is not the best method of measurement because of this. Also dew point instruments normally have limited reliability in on-line applications on annealing furnaces.

With a known hydrogen level, the dew point in the furnace can be calculated. This is provided as an output on a standard Novatech 1638 analyser but we recommend the use of the oxygen output from the same analyser. Both outputs are available simultaneously for operators who are more used to furnace dew point levels. The dew point output however is only an approximate guide if the hydrogen level in the furnace varies.

### 2.7 In-Situ Oxygen Probes

There are very few oxygen probes on the market, which can operate reliably in an annealing furnace atmosphere at furnace temperatures. Novatech probes have been developed in co-operation with BHP steel for annealing furnace applications to provide a reliable measurement for monitoring both continuous and batch furnaces. BHP now have 60 Novatech probes and analysers installed to protect their products during the annealing process. These sensing probes give long life with no need for calibration. The most important feature however is that Novatech oxygen probes measure the oxygen partial pressure just as it occurs at the surface of the steel.

## 2.8 The Zirconia Sensor

The analyser input is provided from a solid electrolyte oxygen probe, which contains a zirconia element and thermocouple. The probe is designed to be inserted into a furnace. Sampling lines and filters are not required for in-situ probes. When a sampling line is required, the sample flows to the sensor under process pressure in most applications. In applications where the process pressure is negative or neutral, a suction pump will be required. A reference air pump is provided in the 1638 oxygen analyser. The internal construction of a probe is shown as follows.

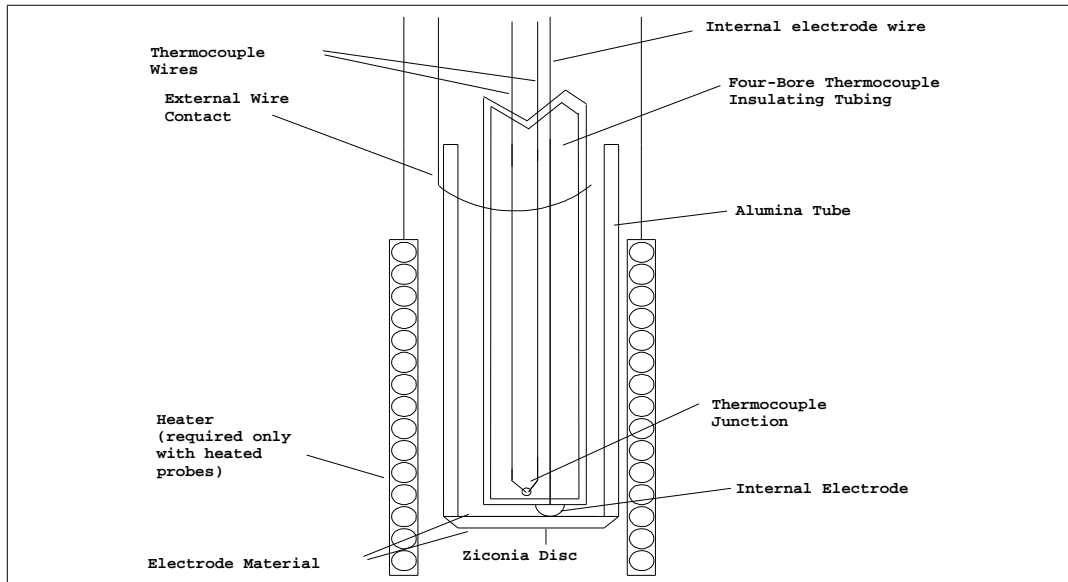

**Schematic View of a Sensor Assembly**

The heater control in the 1638 analysers consists of a time proportioning temperature controller and solid state relay so that the thermocouple junction is controlled to 720°C. Probes operating in a combustion environment above 650°C do not require a heater. When exposed to different oxygen partial pressures at the outside and inside of the sensor, an EMF (E) is developed which obeys the Nernst equation:

$$E \text{ (millivolts)} = \frac{RT}{4F} \log_e \left( \frac{(PO_2) \text{ INSIDE}}{(PO_2) \text{ OUTSIDE}} \right)$$

Where T is the temperature (K) at the disc (>650°C), R is the gas constant, F is the Faraday constant and (PO<sub>2</sub>) INSIDE and (PO<sub>2</sub>) OUTSIDE are the oxygen partial pressures at the inner and outer electrodes, respectively, with the higher oxygen partial pressure electrode being positive.

If dry air at atmospheric pressure, (21 % oxygen) is used as a reference gas at the inner electrode, the following equations are obtained:

$$E \text{ (millivolts)} = 2.154 \times 10^{-2} T \log_e \frac{0.21}{(PO_2) \text{ OUTSIDE}}$$

Transposing this equation

$$(\%O_2) \text{ OUTSIDE (ATM)} = 0.21 \text{ EXP } \frac{-46.421E}{T}$$

The 1638 transmitter solves this equation which is valid above 650°C. The probe heater, or the process maintains the sensor temperature at this level.

## 2.9 The Analyser

The 1638 analyser is a transmitter with two 4 to 20 mA outputs. One output is % oxygen or dew point with selectable zero and span. The second output can be selected as dew point, oxygen, auxiliary temperature or sensor EMF. Four alarm relays are provided. Refer to the sections 4.2 and 4.3 for more details.

The 1638 analyser is designed to operate with either one or two heated or unheated, zirconia probes in one process. If two probes are being used, the analyser can average the two oxygen and dew point signals, alarm when there is a high difference, transmit and display the average and/or individual oxygen signals.

If heated probes are being used, the analyser will maintain the temperature of the sensor(s) at 720°C. The analyser solves the Nernst equation and will provide accurate oxygen measurements up to 1500°C (2730°F), although most probes are suitable only to 1400°C (2250°F). 1231 heated probes are limited to 900°C (1650°F).

## 2.10 Alarms

Refer to OPERATOR FUNCTIONS Section 4 for details on alarm functions.

## 2.11 Heater

### CAUTION

The probe heater is supplied with mains voltage. This supply has electrical shock danger to maintenance personnel. Always isolate the analyser before working with the probe. The EARTH wire (green) from the probe must *always* be connected to earth.

The heater is supplied from the mains power directly, and the temperature is controlled initially at 720° C after turn on.

## 2.12 Applications Where Sensing Point Is Not At Atmospheric Pressure

To apply the 1638 analyser to processes, when the pressure at the point of measurement is significantly above or below atmospheric pressure, then compensation must be applied. (Refer to Set-up Steps 34 and 35 in Section 5.5). If two sensors are being used, they must be close to the same pressure.

## 2.13 Probe Impedance

The probe impedance is a basic measurement of the reliability of the oxygen reading. A probe with a high impedance reading will eventually produce erroneous signals. The analyser regularly checks the probe impedance and if the impedance is above the maximum level for a specific temperature then the impedance alarm will be activated. Typical probe impedance is 1 K $\Omega$  to 8 K $\Omega$  at 720° C.

## 2.14 Auto Calibration - Electronics

The analyser input section is self calibrating. There are no adjustments. The analog to digital converter input stages are checked against a precision reference source and calibrated once every minute. Should the input electronics drift slightly then the drift will be automatically compensated for within the microprocessor. If a large error occurs due to an electronic fault then an 'ADC CAL FAIL' alarm will occur.

A one-off calibration procedure of the precision reference sources should never need to be repeated for the instrument life unless the instrument has been repaired. For a description of the calibration procedure, refer to 'Setting Up The Analyser' Section 5.5, items 7, 8 9 and 10.

The digital to analog converters or output section of the analyser are tested for accuracy every minute and if they are found to have an error then a 'ADC CAL FAIL' alarm will occur. The D/A sections are re-calibrated by pressing the 'AUTO CAL' button on the keyboard while in 'SET-UP' mode.

All output signals will drop to 0 mA for a one second period. It is suggested that a D/A re-calibration be performed after the instrument has stabilised, approximately 30 minutes after first switching on and after Setting Up The Analyser Section 5.5, items 6, 7, 8 and 9 have been completed, and then annually.

## 2.15 Auto Calibration CHECKING - probes

On-line automatic gas calibration check is not normally required. Where it is required however, the probe can be checked for accuracy in-situ and on-line. Solenoid valves can admit up to two calibrated gas mixtures into the probe via solenoid valves under microprocessor control on a timed basis. For details on installation refer Section 3.11. For details on setting up this facility refer to Set-up steps 41 to 53 in Section 5.5.

During probe auto calibration checking, the analyser output will freeze and remain frozen for a further adjustable period, allowing the probe time to recover and continue reading the furnace oxygen level.

Calibration check gases may be manually admitted by pressing the 'CAL' buttons on the keyboard while in 'RUN' mode. The analyser output is frozen during the pressing of these buttons and immediately becomes active when the button is released. If calibration gas checking is enabled in the Set-up menu for either gas, an automatic gas cycle can be started by pressing the 'CAL' buttons in RUN mode. The cycle can be terminated by pressing any other button.

## 2.16 Auto Purge

In steel annealing applications it is expected that the furnace will be gas fired. However, in oil and coal fired plant, it is possible for the probe sensing filter to become blocked. An automatic purge cycle can be set up so that a blast of air or nitrogen, maximum 100 kPa., will automatically back-flush the probe filter on a timed basis. Refer to Set-up steps 36 to 40 in Section 5.5. A purge pressure switch will sense if there is insufficient flow to clear the filter during the purge cycle. In this case a 'PROBE FILTER' alarm will occur. The probe can be manually purged from the keyboard while in 'RUN' mode. The analyser output is not frozen during or after the pressing of this button.

Automatic or manual purge is not available if two probes are being used. However, one of the gas check output could be used to purge the filter.

## 2.17 RS 485 and RS 232C Port

The serial port is for connecting a printer, a data logger, or any computer with an RS485 MODBUS or 232-C port. It can be used to monitor the transmitter and process by logging the values of functions selected in step 70 of the Set-up menu in Section 5.5. The log period may be selected in step 71, and the baud rate may be set in set-up step 72. Alarms, including the time they occurred, will be transmitted to the printer and computer whenever they are first initiated, accepted and cleared. The protocol for the serial port is eight data bits, one stop bit, no parity. Please contact the factory for further details on serial communications with external systems such as computers, DCS's or PLC's. The MODBUS address is set in step 81 of the set-up menu.

## 2.18 Auxiliary Temperature Thermocouple

A furnace thermocouple should also be connected when an additional temperature display or transmitted signal is required. This input is not available if two probes are being used.

## 2.19 Watchdog Timer

The watchdog timer is started if the microprocessor fails to pulse it within any one second period, (ie. fails to run its normal program). The microprocessor will then be reset up to three times until normal operation is resumed. Reset cycles are displayed by the POWER light on the keyboard. A steady 'ON' light indicates normal operation. If the program has not resumed normal operation after three attempts to reset, the common alarm relay will be activated. The reset function will continue repeatedly after the alarm. If a successful reset is achieved, the alarm will be cancelled and the analyser will continue to run normally.

## 2.20 Back-Up Battery

The transmitter's RAM and real-time clock are backed up by a lithium battery in the event of power failure. All set-up variables are saved and the clock is kept running for approximately ten years with the power off. The battery module should be replaced every 8 years. (It is the battery shaped device clipped in a socket labelled M1 on the 1630-1 PCB)



# INSTALLATION & COMMISSIONING

# 3

## SECTION NUMBER

## INSTALLATION

- 3.1 MOUNTING THE ANALYSER
- 3.2 INSTALLING THE OXYGEN PROBE
- 3.3 INSTALLING THE AUXILIARY THERMOCOUPLE
- 3.4 SHIELD CONNECTIONS
- 3.5 ELECTRICAL CONNECTIONS
- 3.6 HEATER INTERLOCK RELAYS
- 3.7 CONNECTING AN OXYGEN PROBE CABLE
- 3.8 CONNECTING THE AUXILIARY THERMOCOUPLE (OPTIONAL)
- 3.9 CONNECTING THE OUTPUT CHANNELS
- 3.10 CONNECTING THE ALARMS
- 3.11 CONNECTING THE AUTOMATIC PURGE & CALIBRATION CHECK SYSTEM
- 3.12 CONNECTING REFERENCE AIR
- 3.13 CONNECTING THE DUAL FUEL INPUT
- 3.14 CONNECTING THE PRINTER
- 3.15 CONNECTING THE ANALYSER TO A MODBUS™ NETWORK

## COMMISSIONING

- 3.16 CONNECTING POWER
- 3.17 COMMISSIONING - SET-UP MODE
- 3.18 COMMISSIONING - RUN MODE
- 3.19 BURNER BY-PASS SWITCH
- 3.20 CHECKING ALARMS
- 3.21 PROBE AND SENSOR CALIBRATION CHECK
- 3.22 FILTER PURGE SET-UP PROCEDURE
- 3.23 CALIBRATION CHECK GAS SET-UP PROCEDURE

## INSTALLATION

### 3.1 Mounting the Analyser

Surface mount the transmitter case on to a flat surface or bracket, using the four mounting brackets provided.

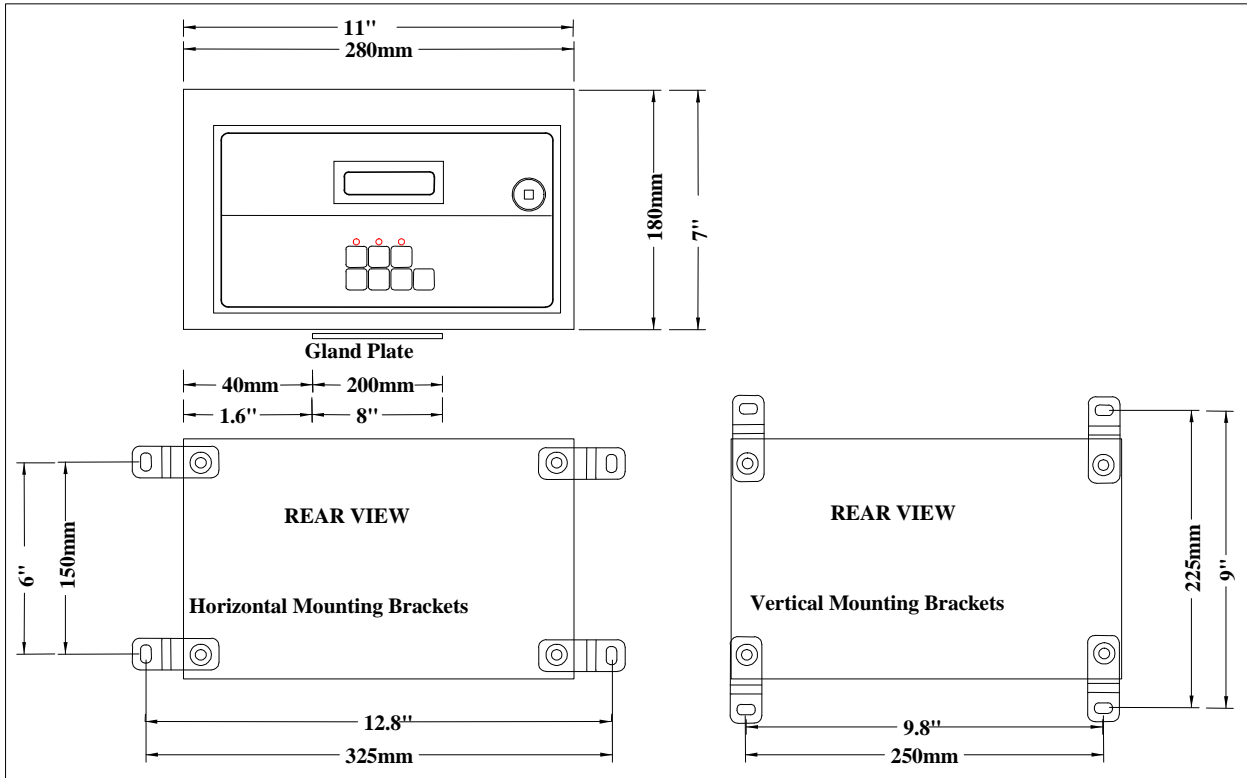

Case Mounting Dimensions

### 3.2 Installing a 1231 Oxygen Probe

Weld a BSP or NPT socket to the furnace in a suitable position for sensing the furnace atmosphere. For the correct size of socket refer to probe data in Section 1. The oxygen probe is normally installed pointing **vertically upwards** in removable cover, coil annealing furnace. Probes can be mounted at any angle. If there are any particulates in the furnace, the filter can be omitted by pointing the probe vertically downwards. Otherwise the filters may have to be replaced periodically.

If installing a probe into a hot environment, slide the probe in slowly to avoid thermal shock to the internal ceramic parts. If the furnace is 1000°C, it should take approximately ten minutes to install a 500 mm. probe, moving it in about 20 mm steps.

#### CAUTION

The oxygen probe should protrude into the furnace at least 25 mm. If the furnace has high velocity fan circulation a filter should be used on 1231 oxygen probes or, in extreme cases, a flow diverting vane. Without a filter or vane the fan velocity can cool the 1231 heater.

Although it is rare, occasionally a probe may sense oxygen vastly differently from the average reading in the furnace. If it occurs, then the probe should be moved, or a longer probe installed. This phenomena is normally caused by stratification of the furnace atmosphere.

### **3.3 Installing the Auxiliary Thermocouple**

Weld a 1/2 inch BSP mounting socket to the furnace within about 300 mm, and upstream of the oxygen probe. The thermocouple should be of similar length to the oxygen probe to prevent furnace temperature distribution errors.

### **3.4 Shield Connections**

All external wiring to the 1638 analyser should be shielded. Do not connect shields at the field end. Simply clip off and insulate. An extra terminal strip may be required to connect all shields together. This should be supplied by the installer.

### 3.5 Electrical Connections

All wiring should comply with local electrical codes. The printed circuit boards are fully floating above earth. All earth and shield connections should be connected to the earth stud on the LHS inside the case. Before connection of mains power check that the 115 / 230 volt power selector switch is set to the correct voltage.

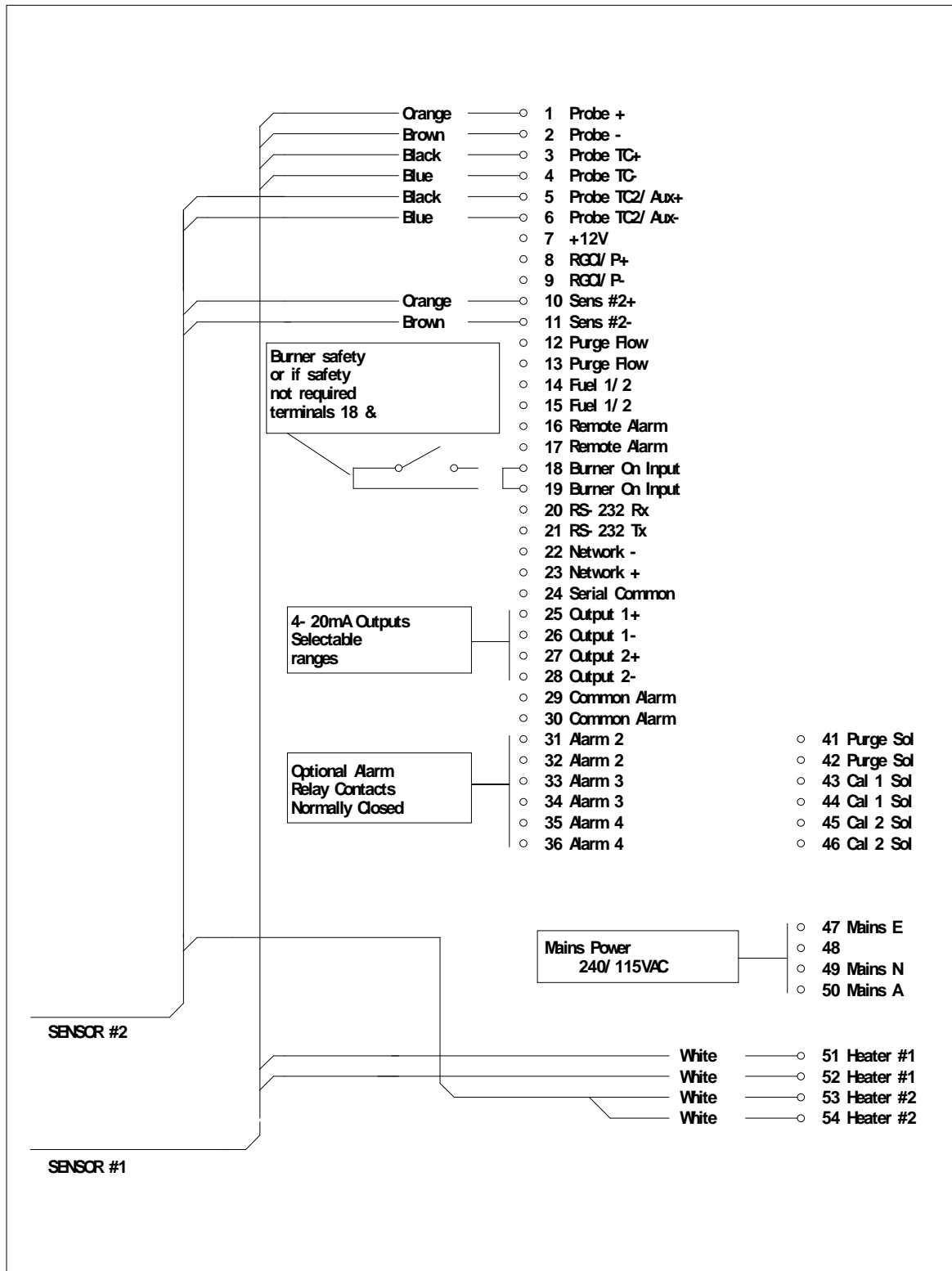

Connection Diagram for 1638 Analyser and one or two 1231 Heated Sensors

All wiring should comply with local electrical codes. The printed circuit boards are fully floating above earth. All earth and shield connections should be connected to the earth stud on the LHS inside the case. Before connection of mains power check that the 115 / 230 volt power selector switch is set to the correct voltage.

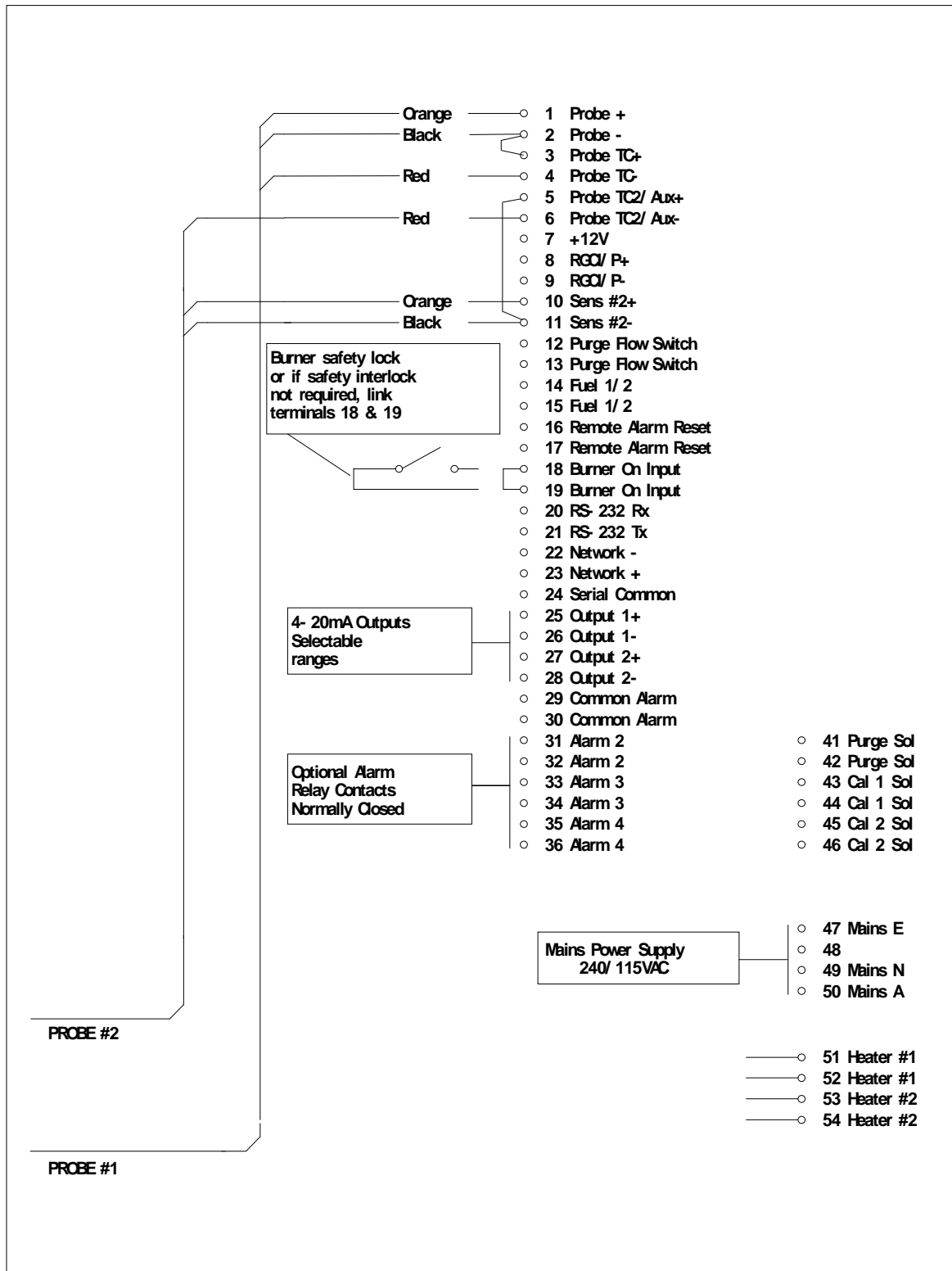

Connection Diagram for 1638 Analyser and one or two 1232 Unheated Sensors

### 3.6 Heater Interlock Relays

#### CAUTION

Explosion protection for heated probes is achieved by switching the power to the probe heater off whenever the main fuel valve is closed.

The principle of safety is that if the main fuel valve is open then main flame has been established. With this primary source of ignition on, the probe heater can be safely switched on. The most dangerous situation is if fuel or hydrogen leaks into the furnace when the fuel valve is closed. When power is removed from the main fuel valve the heater should be switched off.

To achieve this protection, connect a main fuel valve voltage free contact to the 'BURNER ON SWITCH' terminals 18 & 19. When the main fuel valve is open, the voltage free contact should be closed. For installations where there is no risk of explosion, connect a link between terminals number 18 & 19.

#### Heater Supply Interlock Connection For Heated Probes

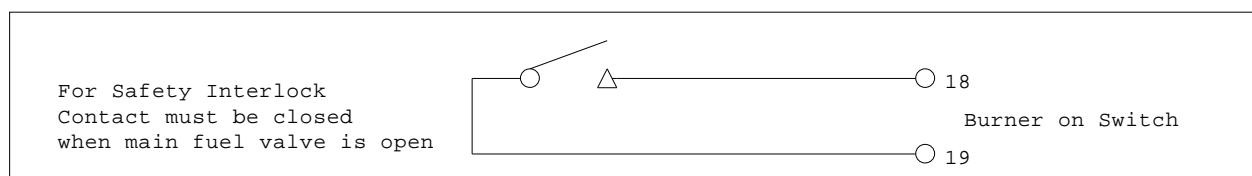

### 3.7 Connecting an Oxygen Probe Cable

Connect the probe lead as shown in the following drawings. Unheated probe leads have integral reference air tube. An adaptor has been supplied to connect this tube to quarter inch flexible PVC tubing, from the air pump or reference air supply.

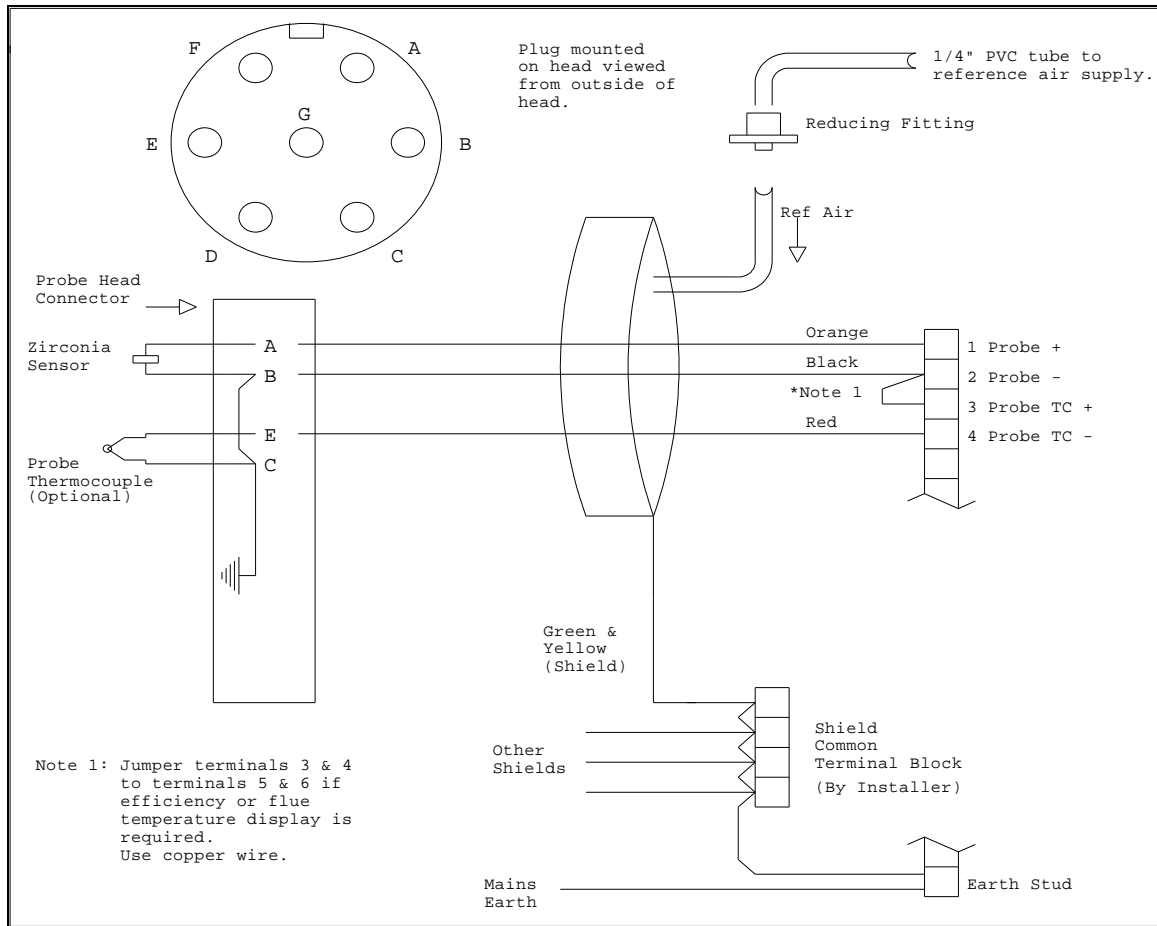

**Connection of Probe Cable for Unheated Probes Model 1232**

**Connection of Probe Cable for Heated Probes Model 1231**

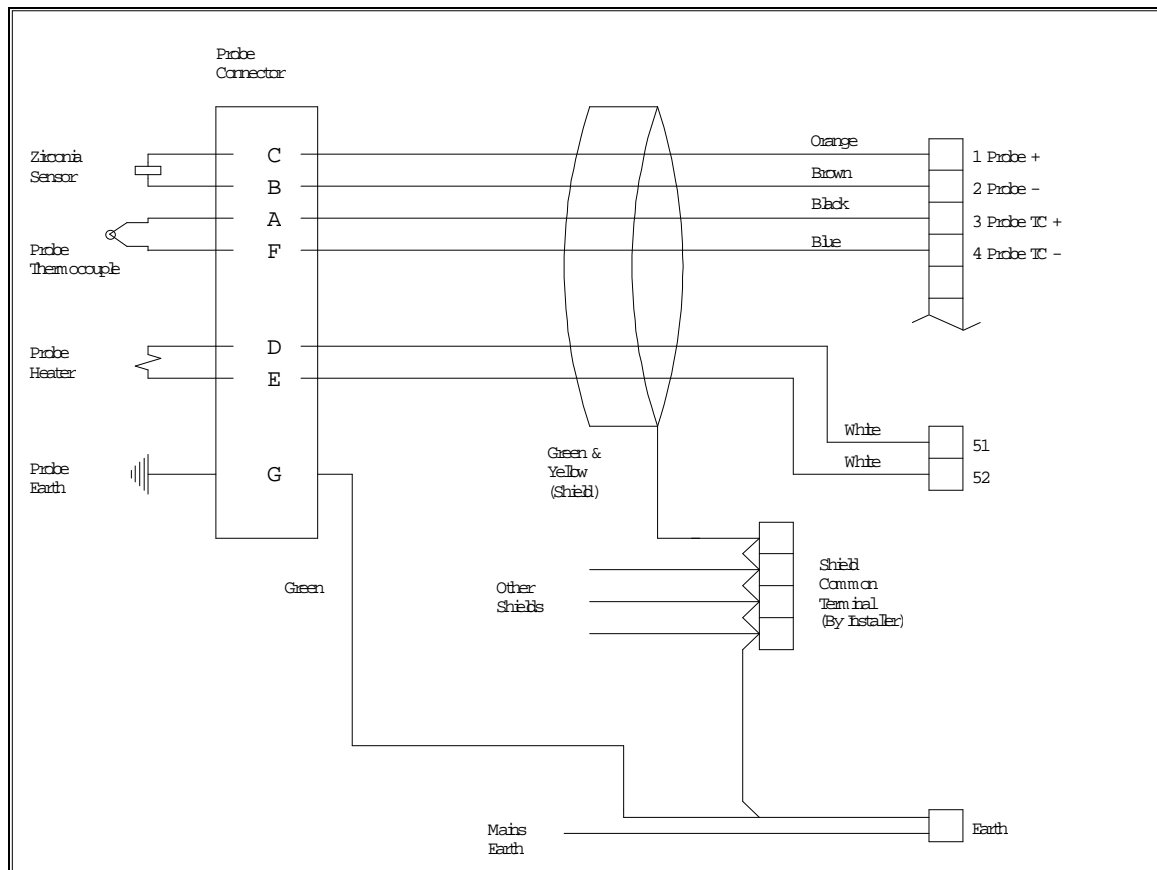

### 3.8 Connecting the Auxiliary Thermocouple (optional)

For 1231 heated probes, the auxiliary thermocouple must be a separate TC with the junction isolated from earth, mounted near to and upstream of the oxygen probe. It can be either type K or R. It is optional. If efficiency, oxygen deficiency or auxiliary temperature display or transmitted signals are not required, then an auxiliary TC is not necessary.

### 3.9 Connecting the Output Channels

The two 4 to 20 mA DC output channels are capable of driving into a 1000Ω load.

### 3.10 Connecting the Alarms

A common alarm, which should be connected for all installations initiates on alarms functions described below. Three additional alarm relays are available for selectable functions as listed in Section 4.2 and 4.3. Each relay has normally closed contacts. The contacts will open in alarm condition except for the optional horn function which operates with normally open contacts. Relays are connected as follows:

Relay	Terminal Numbers
Common Alarm	29 & 30
Alarm 2	31 & 32
Alarm 3	33 & 34
Alarm 4	35 & 36

**Common Alarms** All of the following conditions will cause a common alarm -

- ADC Warning
- DAC Warning
- ADC Calibration Fail
- DAC Calibration Fail
- Sensor 1 Fail
- Sensor 2 Fail \*\*
- Heater 1 Fail
- Heater 2 Fail \*\*
- Sensor 1 TC Open
- Sensor 2 TC Open \*\*
- Aux. TC Open
- Reference Air Pump Fail
- Mains Frequency Check fail
- Probe Filter Blocked
- Gas 1 or 2 Calibration Check Error
- Memory device fail
- Burner bypass Switch on
- Watchdog Timer

The watchdog timer is a special alarm. It will force the common alarm to activate in the event of a microprocessor failure. There will not be an alarm message displayed, but the analyser will reset.

Alarms can be accepted by either pressing the alarm button (viewing the alarm messages), or by temporarily closing a switch connected to terminals 16 & 17, REM ALARM RESET.

**Alarm relay 2 to 4** Select any one or all of the following for each relay. Refer 5 to Section 5.5, steps 54 to 66

- Oxygen Deviation High \*\*
- Dew point Deviation High \*\*
- High oxygen probe 1
- High oxygen probe 2
- High dew point probe 1
- High dew point probe 2
- High oxygen deviation between probes
- High dew point deviation between probes
- Probe under temperature
- Calibration check in progress
- Probe purge in progress
- Alarm horn function (Relay 4 only)

\*\* These alarms are only available if two sensors are selected

### 3.11 Connecting the Automatic Purge and Calibration Check System

#### CAUTION

The purge and calibration solenoid valves are supplied with mains voltage. This supply has electrical shock danger to maintenance personnel. Always isolate the analyser before working with the purge and calibration solenoid valves.

The on-line auto purge and calibration check system is optional. For details on its operation refer to Sections 1.3, 1.4, 2.9 and 2.10.

To automatically sense a blocked probe filter, a pressure sensor should be connected to the 'purge' line to the probe 'cal' port. It should be adjusted so that it energises just above the purge pressure with a new or clean filter installed. The switch contacts should be connected to terminals 12 & 13 (PURGE FL SWITCH).

If the filter is still blocked or partly blocked after an auto purge cycle, the pressure switch will energise and cause a 'Probe Filter Blocked' alarm.

After installation the purge/cal system should be tested thoroughly for leaks. Any leaks can cause significant errors if the furnace is at negative pressure. If the furnace is at positive pressure, an outward leak can cause corrosion in the purge/cal system piping and fittings.

Note: If two probes are being used, the purge is not available, and Cal 2 gas must be connected to probe 2.

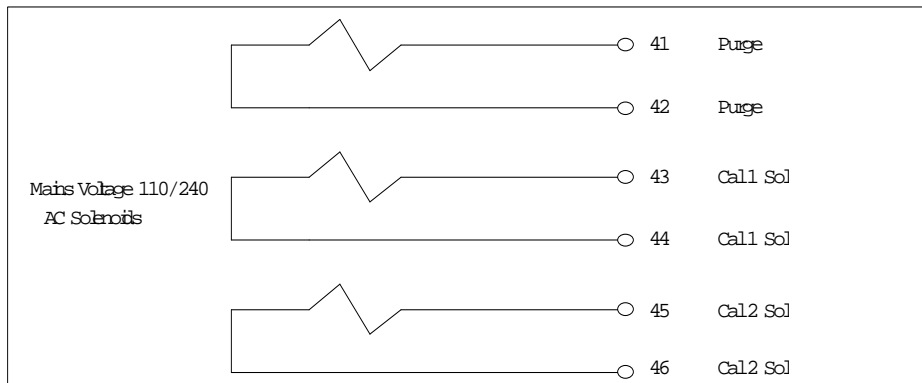

**Automatic Purge & Calibration check System Wiring Schematic**

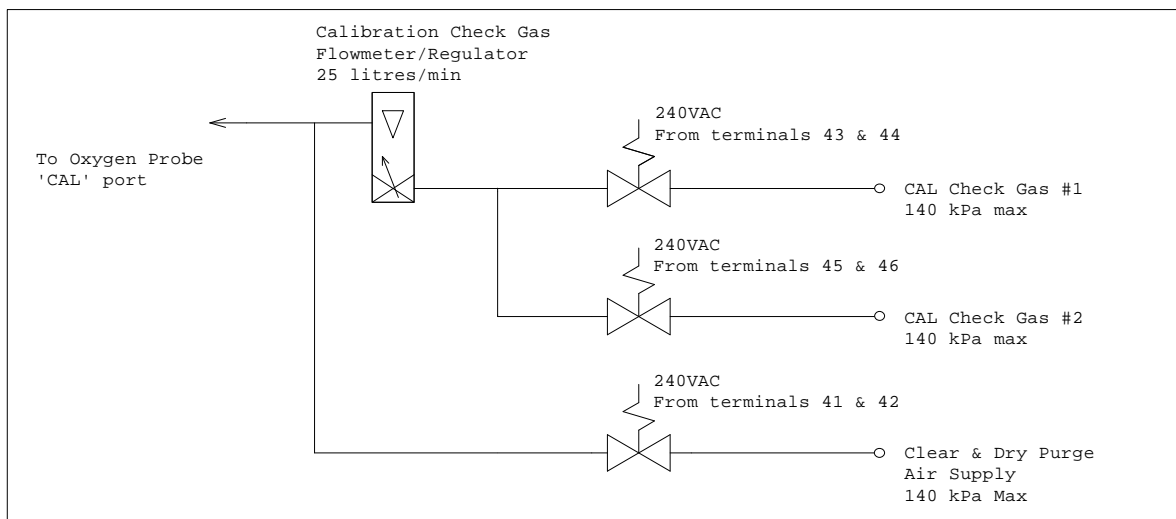

**Automatic Purge & Calibration check System Piping Schematic**

### 3.12 Connecting Reference Air

A 1/4" tube connector on the analyser should be connected via a nylon, copper or stainless steel tube to the 'REF' connector on the probe.

If two probes are being used, a "T" union must be supplied to provide reference air supply to both probes.

### 3.13 Connecting the Dual Fuel Input

If efficiency display is required and the appliance is capable of firing more than one fuel, then an external contact must be connected for the analyser to determine which fuel is being burnt. See Figure 3.12 for details.

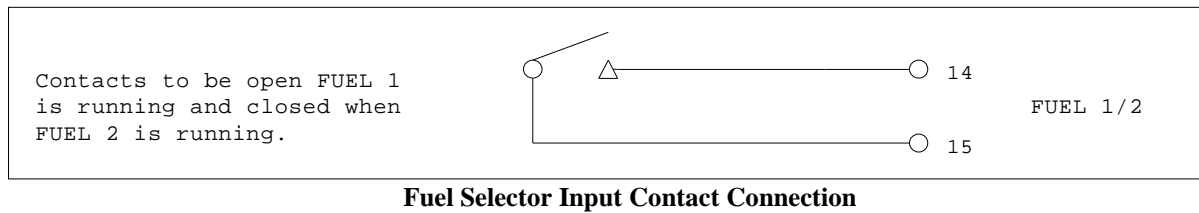

### 3.14 Connecting the Printer

A printer with a serial port, or a data logger, or a computer terminal may be connected to RS 232-C or the network port. Data is logged out of the port as arranged in Set-up steps 70 and 71. The baud rate is selectable in set-up step 72. The RS-232 protocol for the serial port is eight data bits, one stop bit, no parity.

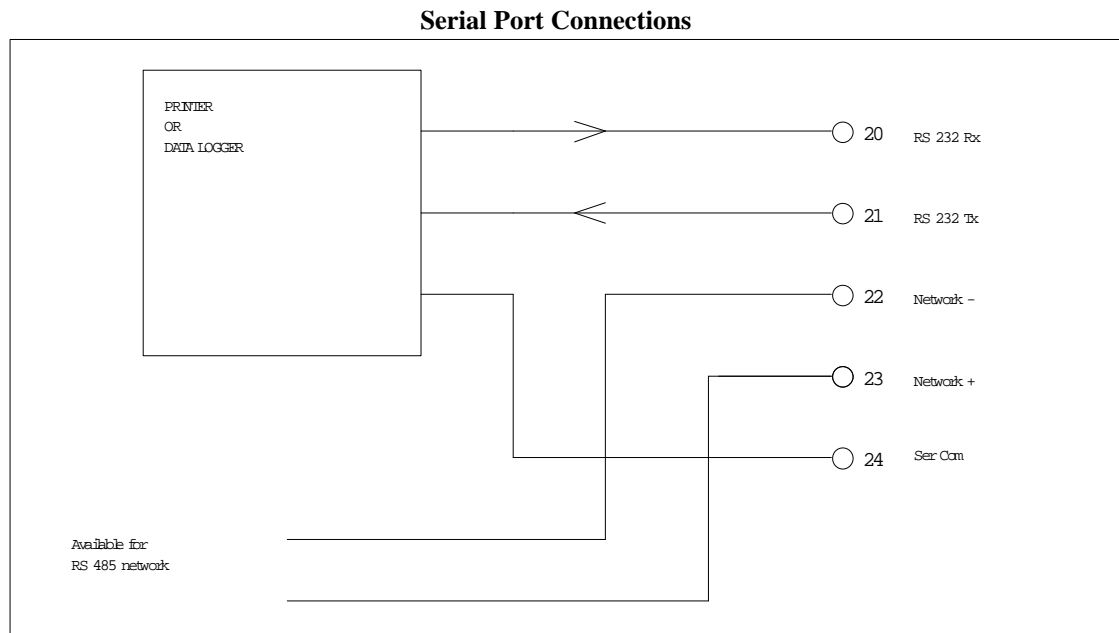

### 3.15 Connecting The Analyser To A Modbus™ Network

The analyser can be networked to other analysers and to a network master. The network uses the analyser RS485 port. Up to 31 analysers can be connected to the network, and can be interrogated by the Network Master.

*NOTE: Hardware Protocol Selection*

For the RS485 port on the analyser to operate, the link LK3 on the 1630-1 printed circuit board (mounted on the door of the analyser) must be set to the RS485 position. The LK3 is accessed by removing the cover from the door PCB. It is located at the bottom of the circuit board.

*NOTE: Terminating Resistor*

There is a terminating 100 ohm resistor fitted to the 1630-1 PCB. Link LK2, in the bottom left-hand corner of the PCB on the door, is used to connect the terminating resistor. Link LK2 must be removed on all analysers except the analyser on the end of the network line. If the network line from the analysers is taken from the middle of the analyser network string, a terminating resistor should be enabled with LK2 at each end of the network line.

The protocol of the network is –

Baud Rate	9600
Parity	none
Stop Bits	1
RS485	Half Duplex
Mode	RTU (binary mode)

For more details see Section 2.12 and Appendix 6.

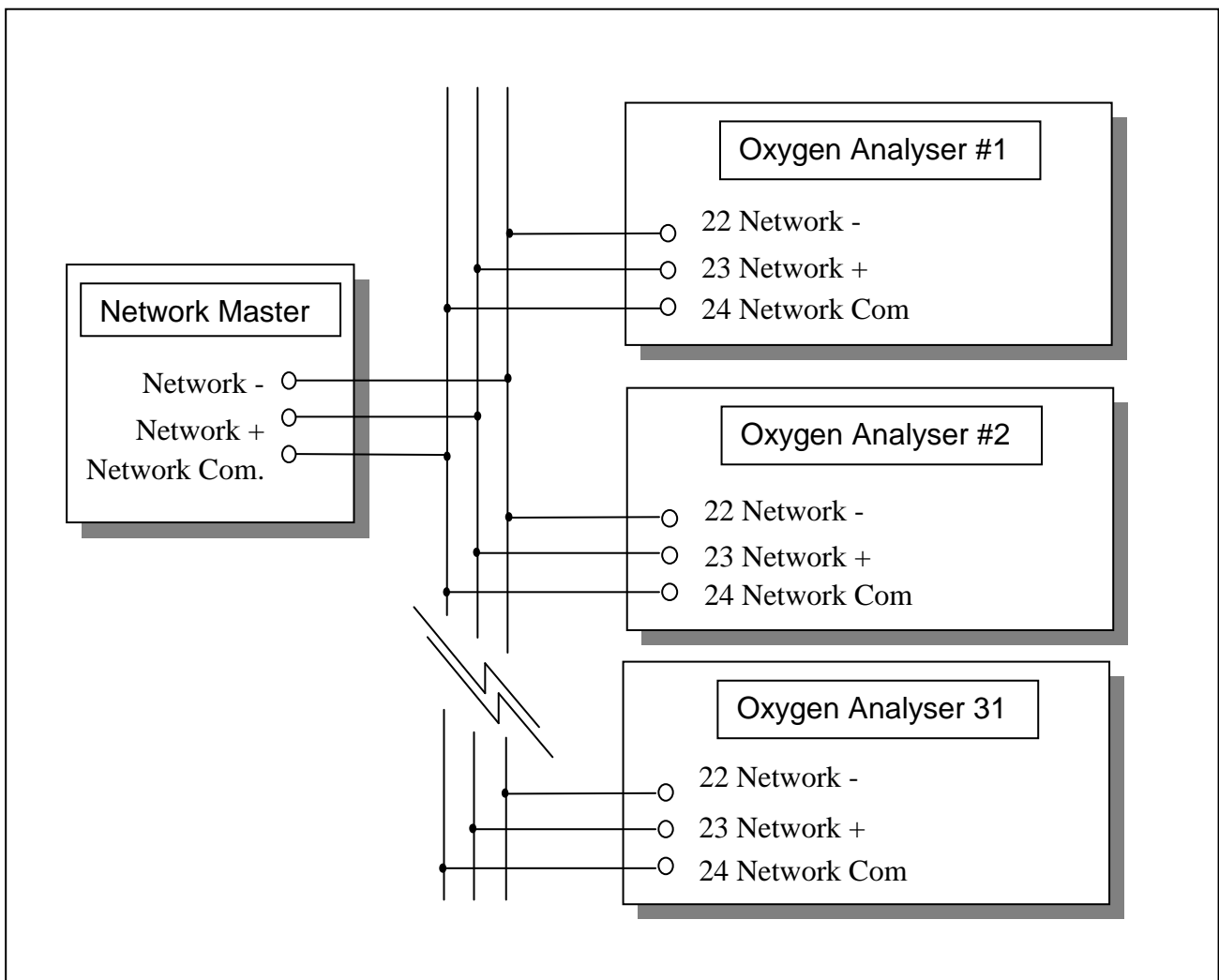

Network Connections

## COMMISSIONING

### 3.16 Connecting Power

Before commissioning the probe, sensor or transmitter, read the CAUTION paragraphs at the front of this manual. Check that the mains supply voltage switch is set for the correct supply voltage, and that the green / yellow EARTH wire MUST be connected to earth.

### 3.17 Commissioning - Set-Up Mode

Press the SET-UP button to select the 'SET-UP' mode. Most of the default settings of the functions will be correct, or will have been pre-set at the factory. Refer to Section 5.5 for more details.

Check the following set-up functions -

2 to 6	Date /time
7 to 10	Reference voltages
11 & 12	Probe offset
22 & 23	Sensor type
26 to 28	Output channel #1
29 to 31	Output channel #2
37	Auto purge
41	Auto gas calibration checking
54 to 69	Alarm set-up
80	Hydrogen level

### 3.18 Commissioning - Run Mode

When the analyser is turned on it will go to RUN mode. The SET-UP/RUN button will toggle between the two modes. The upper line of the display will now read '% OXYGEN'. If the probe temperature is not above 650°C, a "Probe Low Temperature" message will be flashed on the lower line. The probe temperature can be checked on the lower line of the display.

### 3.19 Burner Bypass Switch

Heated probes and sensors should have their heater supply interlocked. If the combustion appliance is not running, then power will not be supplied to the heater. To commission an oxygen probe when the main burner is turned off, switch power off the analyser, remove the probe from the furnace.

Re-apply power to the analyser, press the BURNER BY-PASS switch into the 'DOWN' or 'ON' position. This will apply power to the probe heater even when the plant is not running. The offset can now be set and calibration checked with appropriate calibration check gases (typically 2% oxygen in nitrogen).

Ensure that the burner by-pass switch and the power are turned off before the probe is re-installed. An alarm will occur if the BURNER BY-PASS switch is turned on (down) during normal operation.

### 3.20 Checking the Alarms

If any alarms are present the alarm LED will be lit, either flashing or steady. To interpret the alarms, press the alarm button until all alarm functions have been displayed. Rectify the cause of each alarm until no further alarms appear on the display. For details on the operation of the alarm button and the alarm functions refer to Section 4.

### 3.21 Probe Calibration

The zirconia sensor provides an absolute measurement of oxygen partial pressure. There are no calibration adjustments, apart from 'SENSOR OFFSET', for the probe. The probe EMF is either correct or replacement is required. To check that the probe is functioning correctly, firstly check that the high impedance alarm is not activated causing a 'SENSOR FAIL' alarm. The actual impedance can be displayed on the lower line. It should be less than 9 K $\Omega$  at 720°C.

Once it has been established that the impedance is normal, the offset may be set using the millivolt level marked on the oxygen probe. Refer to Section 5.5.11. The probe offset can be tested on site. A small flow of air must be admitted to both the 'REF' and 'CAL' ports when testing the probe offset. If the probe is in the process, the air must fully purge the probe sensor without interference from the process gas sample.

### 3.22 Filter Purging

Purging probe filters is controlled from the 'PURGE' button on the analyser when in 'RUN' mode. If 'AUTO PURGE' has been enabled in set-up 37, pressing the PURGE button will start the automatic cycle. Pressing any other button will cancel the auto purge cycle. If AUTO PURGE was not enabled, the purge solenoid will only stay open for as long as the button is pressed. Gradually adjust the purge gas supply regulator, increasing the pressure until sufficient flow is obtained to clear the filter. This is best checked with a dirty filter after a period of operation, by withdrawing the probe from service and watching any build up on the filter being blown off at the set pressure. Normally 30 kPa (5 psi) is adequate but the air pressure may be set as high as 100 kPa (15 psi).

### 3.23 Calibration Gas Check

If the installation has a filter purge facility, set this up first. Refer to the previous paragraph. Press the 'CAL 1' or 'CAL 2' button while in 'SET UP' mode to obtain a reasonable flow through the calibration check gas flow meter. If air is being used as a calibration check gas, use the air from the regulator for filter purge. Then, when setting up a gas for calibration checking, set the pressure from the calibration gas cylinder so that it is the same as the pressure set on the air regulator. Then the setting on the rotameter / flow regulator will be the same as that for the air flow. Required flows are about 2 litres per minute.

Air is not the best gas for calibration checking on a zirconia sensor. The output of a zirconia sensor with reference air is zero millivolts. It is better to choose a gas value which provides a reasonable output from the sensor and which is near to the process oxygen level. A cylinder with 2% oxygen in nitrogen is a commonly used calibration gas. The maximum pressure on the calibration check gas cylinder regulators is 100 kPa (15 psi).

Note: If two probes were selected in set-up 1, 'Cal Gas 2' must be connected to probe 2.

### 3.24 Dust in the Furnace

For unheated probes with no filter, entrained solids or dust in the furnace does not present a problem unless the dust, when settled, is not porous. Allow the dust in the process to build up on the probe. It will form a porous layer slowing the response time. To avoid mechanical abrasion of the electrode material in installations with unheated oxygen probes, pack 'SAFFIL' or equivalent alumina based ceramic fibre in the sensing holes to protect the electrode. Do not use silica based ceramic fibres such as 'KAOWOOL', which can attack the electrode at high temperatures. Once the dust has built up the response time of the probe will be slower.

For heated probes the preferred method of mounting for dust laden applications is facing vertically downwards with the filter removed. Probes can also be mounted horizontally with no filter with some dusts. An occasional automatic back purge is helpful in this case.

Normally heated probes are supplied with filters for applications with particulate in the furnace. The probe response time should be tested when the probe is first installed, and then regularly until it remains constant for a significant period. Filter purging should be set up on the time periods determined by these tests. To test the probe response time, use a stop watch to obtain the time for a probe to achieve a 63 % change from one reading to another. If a probe filter blocks completely in a short period of time, then there is no option but to use the probe without the filter.



# OPERATOR FUNCTIONS

## 4

### SECTION NUMBER

4.1	DISPLAY BUTTON
4.2	ALARM BUTTON
4.3	ALARM SCHEDULE
4.4	POWER LAMP
4.5	BURNER BYPASS SWITCH

## OPERATOR FUNCTIONS (RUN MODE)

### 4.1 Display Button

The upper line on the display will always read % oxygen for probe 1. The following are available for display on the lower line.

1. DEW POINT MEASURED BY PROBE 1
2. DEW POINT MEASURED BY PROBE 2 \*\*
3. DEW POINT AVERAGE MEASURED BY PROBES 1 AND 2 \*\*
4. OXYGEN PROBE 2 \*\*
5. OXYGEN AVERAGE OF PROBES 1 AND 2 \*\*
6. SENSOR 1 EMF (millivolts)
7. SENSOR 2 EMF (millivolts) \*\*
8. SENSOR 1 TEMPERATURE
9. SENSOR 2 TEMPERATURE \*\* or AUXILIARY TEMPERATURE
10. SENSOR 1 IMPEDANCE
11. SENSOR 2 IMPEDANCE \*\*
12. AMBIENT TEMPERATURE
13. AMBIENT RELATIVE HUMIDITY
14. DATE / TIME
15. RUN HOURS SINCE LAST SERVICE
16. DATE OF LAST SERVICE

\*\* available when 2 sensors selected in set-up 1

Any number of these variables can be displayed sequentially by pressing the 'DISPLAY' button. Items can be selected for display or deleted in Set-up step 33 on the keyboard. In addition to the above lower line displays, the analyser will automatically display:

"Sensor 1 Temp Low", when probe one is below 650°C

"Sensor 2 Temp Low", when probe two is below 650°C

"Gas 1 ON", "Gas 2 ON" for Calibration check Gas 1 or 2

"Purging Probe"

"Sensor 1 Thermocouple Wrong Polarity"

"Sensor 2 Thermocouple Wrong Polarity"

"Aux Thermocouple Wrong Polarity"

#### NOTE:

1. The run time will be the period of time the BURNER ON SWITCH (terminals 18 & 19) contact is closed (ie. main fuel valve open). If no explosion protection is required, a permanent bridge between the BURNER ON SWITCH terminals will register run time whenever the analyser is powered.
2. This timer can be used as a probe replacement and/or boiler service schedule aid. The start time is reset by changing the 'SERVICE DAY' in set-up mode on the keyboard.
3. If you hold the display button down as you switch on the power, the maximum ambient temperature which the instrument has been subjected to, will be displayed. This temperature should be less than 50°C.

## 4.2 Alarm Button

Repeatedly pressing the 'ALARM' button will produce alarm displays in sequence on the lower line of the LCD display. If an alarm has cleared prior to pressing the 'ALARM' button, it will not re-appear on a second run through the alarms. Active alarms which have been previously displayed will have 'acc' (accepted in lower case), displayed alongside. New alarms will not have 'ACC' (in upper case) displayed until a second press of the 'ALARM' button. After the last active alarm is indicated, the lower line of the display will return to the last displayed lower line variable. Alarms may also be accepted remotely by a temporary closure of a switch connected to terminal 16 & 17, 'REMOTE ALARM RESET'.

The alarm 'LED' will flash when there is an un-accepted alarm. Pressing the 'ALARM' button will cause the LED to go steady if any alarms are still active, or extinguish if there are no active alarms. The horn relay will operate when an alarm occurs. Pressing 'ALARM' will mute a horn relay (if one of the user configurable relays have been selected as a 'Horn' relay) which will re-initiate on any new alarms.

## 4.3 Alarm Schedule

### 4.3.1 Summary of Alarms - COMMON ALARM

1. 'Sensor 1 Fail'

2. 'Sensor 2 Fail'

Oxygen cell or electrode failure (high impedance), (inhibited under 650°C).

3. 'Heater 1 Fail'

4. 'Heater 2 Fail'

In the first 20 minutes of power being applied to the heater after being switched on, this alarm will not occur, but a 'Sensor # Lo Temp' display will occur and common alarm relay will be activated. Refer to Section 6.11. If an ADC alarm occurs, the heaters will automatically be turned off.

5. 'Sensor 1 TC Open'

6. 'Sensor 1 TC Open'

Probe thermocouple is open circuit. The heater in heated probes will switch off.

7. 'Aux TC Open'

Stack thermocouple is open circuit. If the thermocouple is not needed, select "NO T/C" for "Aux TC Type" or place a short circuit between terminals 5 & 6.

8. 'Ref Pump Fail'

The reference air pump in the analyser has failed.

9. 'ADC Cal Fail'

The analog to digital converter has been found to fall outside the normal calibration specifications. In this case the probe heater will automatically be turned off.

10. 'Mains Freq'

The sample of the mains frequency has failed.

11. 'DAC Cal Fail'

The digital to analog and voltage isolator circuit has been found to fall outside the normal calibration specifications. This check is only performed when the 'AUTO CAL' button is pressed. Refer to Section 6.3.

12. 'Probe Filter'

Blocked probe filter. This test is only performed when automatic purging of the probe is requested. Refer to step 36 in the set-up menu Section 5.5. This alarm will not reset until the next purge cycle which can be initiated manually or automatically.

13. 'Gas 1 Cal Err'

Probe does not correctly calibrate to calibration check gas 1.

14. 'Gas 2 Cal Err'

Probe does not correctly calibrate to calibration check gas 2.

15. 'Burner bypass'

The safety interlock relay has been bypassed by turning on the 'BURNER BYPASS' switch on the terminal printed circuit board. Refer to Section 3.18

16. 'Watchdog Timer'

Microprocessor error. This alarm will not appear on the display. The common alarm relay will be forced open circuit. If the watchdog timer senses a malfunction in the microprocessor, it will attempt to reset the analyser every 2 seconds. After two resets the alarm relay contacts will go open circuit.

17. 'BB RAM Fail'

The battery backed memory module has failed in service. The device normally lasts 10 years. It is the plug-in battery like module on the 1630 -1 board, labelled M1.

### 4.3.2 Summary of Alarms - SELECTABLE ALARMS

NOTE: The process alarms must be enabled in set-up 54 if required.

There are three user configurable alarm relays. Any or all of the following functions can be selected for each relay.

18. 'Dew Point 1 High'

The dew point measured by probe 1 (Dew Point 1 High) is above the limit set in set-up 59, and has been there for longer than the time set in set-up 60.

19. 'Dew Point 2 High'

The dew point measured by probe 2 (Dew Point 2 High) is above the limit set in set-up 61, and has been there for longer than the time set in set-up 62.

20. 'Oxygen % 1 High'

The oxygen measured by probe 1 (Oxygen % 1 High) is above the limit set in set-up 55, and has been there for longer than the time set in set-up 56.

21. 'Oxygen % 2 High'

The oxygen measured by probe 2 (Oxygen % 2 High) is above the limit set in set-up 57, and has been there for longer than the time set in set-up 58.

22. 'Oxygen % deviation High'

The oxygen difference measured by probe 1 and 2 is above the limit set in set-up 65, and has been there for longer than the time set in set-up 66.

23. 'Dew point deviation High'

The dew point difference measured by probe 1 and 2 is above the limit set in set-up 63, and has been there for longer than the time set in set-up 64.

24. 'Probe Temperature'

The probe temperature is under 650°C. The oxygen and dew point readings are therefore invalid. If the sensor heater has been on for more than 20 minutes and the temperature is less than 650°C a 'heater fail' alarm will occur.

NOTE:

The 'Probe Temp' relay function is used with unheated probes to indicate oxygen reading is invalid (the probe is below 650°C), in case the process temperature falls below this level. For heated probes this relay will be energised while the probe is heating up from ambient.

25. 'Cal in Progress'

A calibration check is occurring, either manual ( in RUN mode) or automatic

26. 'Probe Purge'

A probe purge is occurring, either manual ( in RUN mode) or automatic

27. Alarm Horn

This is not an alarm condition. If one of the three user configurable alarm relays have 'Alarm Horn' enabled, the relay will have closed contacts only when there is an un-accepted alarm on the analyser. Press the alarm button twice to accept any new alarm and to cancel the horn relay. This is only available on relay 4.

### 4.3.3 Alarm Relays

The alarm relays are fail safe. That is, the contacts will be closed during normal operation, and will be open circuit if there is an alarm or if the power is removed from the analyser.

#### **4.4 Power Lamp**

Illuminates when power is connected to the analyser. If the lamp is flashing, the watchdog timer is attempting to reset the microprocessor. Replace the 1630-1 microprocessor PCB.

#### **4.5 Burner Bypass Switch**

This switch is mounted on the terminal PCB near the POWER switch.

Before the heater in a heated probe, or the alarms will be enabled, the probes must be enabled. There are two ways of doing this.

Use the safety interlock on terminals 18 & 19 (BURNER ON switch), or press the BURNER BYPASS switch to the ON position. While the BURNER BYPASS switch is on there will be an alarm, "Burner Bypass".

If it is not needed to have the analyser interlocked with the combustion appliance terminals 18 & 19 can be connected together.



# SETTING UP THE ANALYSER

## 5

### SECTION NUMBER

- 5.1 SET-UP MODE SUMMARY
- 5.2 SET-UP & RUN MODES
- 5.3 FUNCTION SELECT
- 5.4 ENTER OPTION OR VALUE
- 5.5 SET-UP FUNCTION DETAILS

## SET-UP MODE SUMMARY

### 5.1 Set-Up Mode Functions

- 1 Number of Sensors
- 2 Calender Year
- 3 Calender Month
- 4 Calender Day
- 5 Real time clock Hour
- 6 Real time clock Minutes
- 7 Reference voltage #1
- 8 Reference voltage #2
- 9 Reference voltage #3
- 10 Reference voltage #4
- 11 Sensor 1 offset
- 12 Sensor 2 offset
- 13 Output channel number 1 calibration
- 14 Output channel number 1 calibration, 4mA trim
- 15 Output channel number 1 calibration, 20mA trim
- 16 Output channel number 2 calibration
- 17 Output channel number 2 calibration, 4mA trim
- 18 Output channel number 2 calibration, 20mA trim
- 19 Service record year
- 20 Service record month
- 21 Service record day
- 22 Sensor 1 Type
- 23 Sensor 2 Type
- 24 Sensor 1 Thermocouple Type
- 25 Sensor 2, Auxiliary Thermocouple Type
- 26 Transmitter Output Channel 1 scale
- 27 Transmitter Zero Channel 1
- 28 Transmitter Span Channel 1
- 29 Transmitter Output Channel 2 scale
- 30 Transmitter Zero Channel 2
- 31 Transmitter Span Channel 2
- 32 Centigrade/Fahrenheit Selection
- 33 Lower Line Display Functions
- 34 Flue Pressure mm/inches/kilopascals
- 35 Flue Pressure Value

- 36 Purge/Cal Time
- 37 Automatic Purge

Set-up steps 38 to 40 will be skipped automatically if 'No' is selected in set-up step 37.

- 38 Time Between Purges
- 39 Purge Duration
- 40 Purge Freeze Time

- 41 Number of Cal Gases

Set-up steps 42 to 47 may be skipped automatically, depending on the selection in set-up step 41.

- 42 Oxygen Content of Cal Gas 1
- 43 Maximum Acceptable Positive Error Gas 1
- 44 Maximum Acceptable Negative Error Gas 1
- 45 Period Between Gas 1 Autocal
- 46 Duration of Autocal Gas 1
- 47 Freeze Time Gas 1

- 48 Oxygen Content Of Cal Gas 2
- 49 Maximum Acceptable Positive Error Gas 2
- 50 Maximum Acceptable Negative Error Gas 2
- 51 Period Between Gas 2 Autocal
- 52 Duration of Autocal Gas 2

- 53 Freeze Time Gas 2
- 54 Process alarm enable

Set-up steps 55 and 66 may be skipped automatically, depending on the selection in set-up steps 54 and 85.

- 55 High oxygen alarm sensor #1 level
- 56 High oxygen alarm sensor #1 delay time
- 57 High oxygen alarm sensor #2 level
- 58 High oxygen alarm sensor #2 delay time
- 59 High dew point sensor #1 level
- 60 High dew point sensor #1 delay time
- 61 High dew point sensor #2 level
- 62 High dew point sensor #2 delay time
- 63 High dew point deviation level
- 64 High dew point deviation delay time
- 65 High oxygen deviation level
- 66 High oxygen deviation delay time

Set-up steps 67 and 70 may be skipped automatically, depending on the selection in set-up steps 54 and 85.

- 67 High pre-reaction oxygen warning alarm sensor #1 level
- 68 High pre-reaction oxygen alarm sensor #1 level
- 69 High pre-reaction oxygen warning alarm sensor #2 level
- 70 High pre-reaction oxygen alarm sensor #2 level
  
- 71 Alarm relay number 2 function select
- 72 Alarm relay number 3 function select
- 73 Alarm relay number 4 function select

- 74 Data to Print
- 75 Print Log Period
- 76 Printer Baud Rate

- 77 Reference air pump mode selection

Set-up steps 78 may be skipped automatically, depending on the selection in set-up step 77.

- 78 Reference air RH
  
- 79 Damping factor
- 80 Digital output filter enable

- 81 External hydrogen level input enable

Set-up steps 82 and 83 may be skipped automatically, depending on the selection in set-up step 81.

- 82 External hydrogen level input zero level
- 83 External hydrogen level input span level

Set-up step 84 may be skipped automatically, depending on the selection in set-up step 81.

- 84 Fixed hydrogen level
  
- 85 Instrument operating mode. Pre-reaction oxygen or Dew point
- 86 MODBUS address, 0 for no MODBUS communications

## 5.2 Set-Up & Run MODES

For the SET-UP mode keyboard to operate, press the SET-UP / RUN button. The set-up light will come on when the set-up mode has been entered.

### NOTE:

Set-up mode cannot be entered if the keyboard lock switch on the inside of the analyser is in the UP position. The keyboard lock switch can be found on the door PCB (1630-2), on the lock side, at the top. If access is attempted while the keyboard is locked, the message **'Illegal Access'** will be displayed.

The temperature of a heated probe may fall if the set-up mode is used for more than 2 minutes.

While the analyser is in set-up mode the outputs will be frozen. All the of the functions written in BLUE will now operate. If there are not any buttons pressed for 1 minute the analyser will automatically revert to RUN mode.

If purges or an auto-calibration check occurs while the analyser is in set-up mode, they will be delayed until the analyser is returned to RUN mode.

To cancel an automatic purge or calibration check cycle, press AUTO CAL button while in RUN mode.

### 5.3 Function Select

When the SET-UP mode is entered, the analyser will automatically read the last set-up function selected.

To select other functions, operate the 'FUNCTION ▲' button to increment to the next function, or 'FUNCTION ▼' to decrement to the previous function.

### 5.4 Enter Option or Value

#### A. Options.

To step through the available options for each function press the 'OPTION ▲' or 'OPTION ▼' buttons. When the required option is selected press the 'ENTER' button. An asterisk will then appear alongside the option selected. When stepping through the set-up functions, the display will always first indicate the last options entered. The 'Lower Line Select' and 'Data To Print' set-up items 33 and 70 are multiple options. One or more options may be selected for these functions.

#### B Values

To set a value for a particular function press the 'OPTION ▲' button to increase the value and the 'OPTION ▼' button to decrease the value. A momentary press will change the value one digit. Holding the button will change the value more quickly. Once the correct option or value is displayed it can be entered into the analyser's memory by pressing the 'ENTER' button. When a value has been entered an asterisk will appear at the R.H.S. of the lower line.

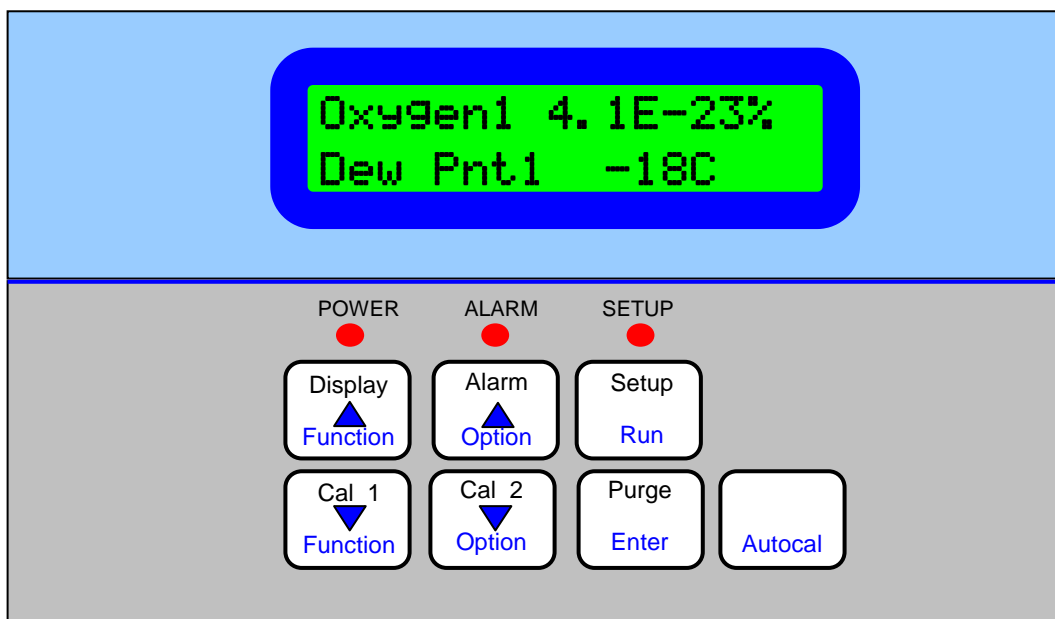

1638 Oxygen Analyser Keyboard

### 5.5 Set-Up Function Details

**Note:** The \* indicates the default setting after a COLD-START. See Section 6.1

#### 1. Number of sensors

##### Options

Select the number of oxygen probes or sensors being used.

- 1 Sensor \*
- 2 Sensors

#### 2. Calendar year

##### Options

Select the current year for the real time clock/calendar.

The cold start default sets the date and time to the software version date.

### 3. Calender month

#### Options

Select the current month for the real time clock/calender.

### 4. Calender day

#### Options

Select the current day for the real time clock/calender.

### 5. Real time clock hour

**Options** Select the current hour for the real time clock. (24 hour format)

### 6. Real time clock minutes

#### Options

Select the current minutes for the real time clock.

### 7. Reference voltage # 1 ( about 27.5 mV's )

#### Options

Set the value of the reference voltage as read on a 3 1/2 digit multimeter (See Section 6.2 for further details).

27.55 mV \*

### 8. Reference voltage # 2 ( about 194 mV's )

#### Options

Set the value of the reference voltage as read on a 3 1/2 digit multimeter (See Section 6.2 for further details).

193.60 mV \*

### 9. Reference voltage # 3 ( about 1200 mV's )

#### Options

Set the value of the reference voltage as read on a 3 1/2 digit multimeter (See Section 6.2 for further details).

1202.00 mV \*

### 10. Reference voltage # 4 ( about 2500 mV's )

#### Options

Set the value of the reference voltage as read on a 3 1/2 digit multimeter (See Section 6.2 for further details).

2479.00 mV \*

Set-up items 7 to 10 are used to calibrate the A/D of the instrument. This should be done 30 minutes or more after the instrument has been on. The calibration constants are retained in battery backed memory unless a 'COLD START' is performed. Connect a 3 1/2 digit multimeter negative lead to the test point marked 'C' to the right of the PCB on the inside of the door (labelled 'REF VOLTS'). Measure the four voltages on the test point marked 1 to 4 with the positive lead. Refer to Figure 6.2 in the 1638 manual. Enter the measured values in set-up items 7 to 10. Whenever new values are entered the D/A section should be re-calibrated, Refer to Section 6.3.

### 11. Set Probe Or Sensor 1 Offset

### 12. Set Probe Or Sensor 2 Offset (When 2 sensors are selected in set-up 1)

A new EMF offset must be entered whenever a new oxygen probe or sensor is installed to calibrate for any offset an individual probe or sensor may have. Each probe or sensor will have an offset value noted on a removable tag. Enter the 'SENSOR OFFSET' value with the underline polarity, eg. if offset value is -1.2 mV. enter -1.2 mV. The typical maximum is 2mV.

To check a probe or sensor offset on site, the probe or sensor must be sensing air with reference air and allowed to settle at the probe operating temperature for 30 minutes. Read the offset in 'RUN' mode in millivolts on the lower line. Offset errors can occur if the sensor does not have some air passing over it. A gentle flow of air in the calibration check port can be provided by a reference air pump or similar.

For heated probes or sensors, if the combustion appliance is not operational and the probe or sensor heater is interlocked with the 'BURNER ON' signal, the 'BURNER BYPASS' switch should be set to 'ON' to power the probe heater after removing the probe from the flue.

## CAUTION DANGER

Return the 'BURNER BYPASS' switch to normal (off) before installing the probe in the flue.

For unheated probes, the probe sensing tip must be raised to at least 650°C with a portable furnace. (Available as an accessory).

Determine the probe or sensor offset in 'RUN' mode. Select 'Sensor EMF' on the lower line. With probe in air, stabilised at temperature for 30 minutes, read the 'Sensor EMF'. Switch back to 'set-up' mode and enter 'Sensor Offset' of equal value and the same polarity.

eg. If the measured 'SENSOR OFFSET' was -1.2 mV, enter -1.2 mV.

When reading the EMF offset, the flue pressure compensation must be set. If the probe has been removed from the flue, set the flue pressure compensation to 0 in set-up step 35.

### 13. 4 to 20 mA Calibration Options, Channel #1

Select the calibration method for the 4-20mA output channel #1.

The output channels can be either calibrated by simply pressing the 'AUTO CAL' button, or can be trimmed at both the 4mA and 20mA ends of the scale using an external multimeter.

#### Options:

1. Auto Calibration \*
2. Manual Calibration
3. Set 4mA Trim
4. Set 20mA Trim

If 'AUTO CAL' is selected, the output channel is calibrated when 'Auto Cal' is initiated from the keyboard (See section 6.3).

If 'MAN CAL' is selected, it is necessary to trim both ends of the 4-20mA output range using the 4mA and 20mA options in this menu item. Selecting 'MAN CAL' inhibits the 'Auto Cal' process of this channel.

Always do the 4mA trim first, and then the 20mA trim. After trimming both ends of the scale, return the 'CALIBRATION OPTIONS' menu option back to 'MAN CAL' (not 'AUTO CAL'), or the calibration factors will be over written by the next 'AUTO CAL'.

For more details on calibrating the output channels, see section 6.3.

NOTE: If the analyser will only stay in either '4mA TRIM' or '20mA TRIM' modes for 30 minutes before it automatically returns to 'MAN AL'.

### 14. Calibrate 4mA, Channel #1

This menu item only appears if 'Set 4mA Trim' is selected in Set-up 13.

**Range:** 0 to 25mA, Default is 4.00mA

For full details on the calibration of the 4-20mA output channels, see section 6.3.

### 15. Calibrate 20mA, Channel #1

This menu item only appears if 'Set 20mA Trim' is selected in Set-up 13.

**Range:** 0 to 25mA, Default is 20.00mA

### 16. 4 to 20 mA Calibration Options, Channel #2

Select the calibration method for the 4-20mA output channel #1.

For more details, see Set-up 13 and section 6.3.

#### Options:

1. Auto Calibration \*
2. Manual Calibration
3. Set 4mA Trim
4. Set 20mA Trim

### 17. Calibrate 4mA, Channel #2

This menu item only appears if 'Set 4mA Trim' is selected in Set-up 16.

**Range:** 0 to 25mA, Default is 4.00mA

For full details on the calibration of the 4-20mA output channels, see section 6.3.

## 18. Calibrate 20mA, Channel #2

This menu item only appears if 'Set 20mA Trim' is selected in Set-up 16.

**Range:** 0 to 25mA, Default is 20.00mA

## 19. Enter Service Year

For a new 'DATE OF LAST SERVICE', enter the service 'YEAR'. This can represent the last time the probe or sensor was serviced or the last time the boiler was serviced. It is recommended that probes and sensors be refurbished every two years

## 20. Enter Service Month

Enter the current 'MONTH'.

## 21. Enter Service Day

End the current 'DAY' of the month. Altering these values will reset the 'RUN TIME'.

## 22. Sensor 1 Type

## 23. Sensor 2 Type

### Options

Model No.                      Enter the probe or sensor model number in use

1. 1231/1234 Heated	*	Heated Probe or sensor
2. 1232 Unheated		Unheated Probe

## 24. Probe Or Sensor 1 Thermocouple Type

## 25. Probe or Sensor 2 Thermocouple Type (When 2 sensors are selected in set-up 1)

### Auxiliary Thermocouple Type (When 1 sensor is selected in set-up 1)

The probe can have either a type K, R, or N thermocouple as a sensor temperature detector. A 1231 probe or a 1234 sensor will always have a K thermocouple, and a 1232 will usually have an R thermocouple.

### Options

1. K	*	Check in the manual Section 1
2. R		for the probe model number.
3. NO T/C		If no TC type is to be used for an Auxiliary use.

## 26. Transmitter Output Channel 1

Select the type of output required from Channel 1. All of the outputs from channel #1 are signals generated from probe #1, even if two sensors are selected in set-up 1. Normally dew point would be selected as the prime output signal. The reducing output is fixed at 10<sup>-16</sup> % to 10<sup>-30</sup> % oxygen to cover the range of dew point readings. For the range of the outputs see the table below.

### Options:

1. Linear oxygen probe 1		
2. Reducing oxygen, probe 1		
3. Dew point, probe 1	*	(only available if Dew point is selected in set-up 85)
4. Pre-reaction oxygen, probe 1	*	(only available if Pre-reaction is selected in set-up 85)
5. Linear oxygen probe 1 and 2 averaged		(only available if 2 sensors are selected in set-up 1)
6. Reducing oxygen, probe 1 and 2 averaged		(only available if 2 sensors are selected in set-up 1)
7. Dew point, probe 1 and 2 averaged		(only available if 2 sensors are selected in set-up 1 and if Dew point is selected in set-up 85)
8. Pre-reaction oxygen, probe 1 and 2 averaged		(only available if 2 sensors are selected in set-up 1 and if Pre-reaction is selected in set-up 85)
9. No Output		

Note:

The average dew point, pre-reaction oxygen, linear O<sub>2</sub> and Reducing O<sub>2</sub> selections will automatically select the operating probe if one probe fails, or selects probe 1 if both probes fail.

## 27. Transmitter Zero Channel 1

Select transmitter zero for output Channel 1. See table below.

## 28. Transmitter Span Channel 1

Select transmitter span for output Channel 1. See table below.

Output	Zero Range	Span Range	Default Setting
LINEAR OXYGEN #1	0 to 99% oxygen	1 to 100% oxygen	0 to 100%
REDUCING OXYGEN #1	10 <sup>-16</sup> % fixed	10 <sup>-30</sup>	10 <sup>-16</sup> to 10 <sup>-26</sup>
DEW POINT #1	-60 to +20 °C -76 to +68 °F 1 ° steps	-40 to +40 °C -8 to +104 °F 1 ° steps	-60 to +40 °C
PRE-REACTION OXYGEN #1	0 oxygen fixed	1 to 10.0% oxygen	0 to 4.0%
LINEAR OXYGEN #1 and #2	0 to 99% oxygen	1 to 100% oxygen	0 to 100%
REDUCING OXYGEN #1 and #2	10 <sup>-16</sup> %	10 <sup>-30</sup>	10 <sup>-16</sup> to 10 <sup>-30</sup>
DEW POINT #1 and #2	-60 to +20 °C -76 to +68 °F 1 ° steps	-40 to +40 °C -8 to +104 °F 1 ° steps	-60 to +40 °C
PRE-REACTION OXYGEN #1 and #2	0 fixed oxygen	1 to 10.0% oxygen	0 to 4.0%

Note:

The last four items (average of probe 1 and 2) are only available if two sensors are selected in set-up 1

## 29. Transmitter Output Channel 2

Select transmitter output for output Channel 2.

### Options:

1. Linear oxygen % probe 2 ( or probe 1, if 1 sensor is selected in set-up 1)
2. Reducing oxygen, probe 2 ( or probe 1, if 1 sensor is selected in set-up 1)
3. Dew point, probe 2 ( or probe 1, if 1 sensor is selected in set-up 1)
4. Pre-reaction oxygen, probe 2 (only available if 2 sensors are selected in set-up 1 and if Pre-reaction is selected in set-up 85)
5. EMF sensor 1
6. EMF sensor 2 ( not available if 1 sensor is selected in set-up 1)
7. Auxiliary thermocouple set-up 25) ( not available if 2 sensors are selected in set-up 1, or if NO TC is selected in set-up 25)
8. No Output

## 30. Transmitter Zero Channel 2

The output zero and span of Channel 2 is set in set-up steps 30 and 31. Range limits are shown below.

## 31. Transmitter Span Channel 2

Output	Zero Range	Span Range	Default Setting
LINEAR OXYGEN #2	0 to 99% oxygen	1 to 100% oxygen	0 to 100%
REDUCING OXYGEN #2 (see Note 1)	10 <sup>-1</sup> to 10 <sup>-25</sup> % oxygen in one decade steps,	10 <sup>-5</sup> to 10 <sup>-30</sup> % oxygen in one decade steps. Min span five decades.	10 <sup>-16</sup> to 10 <sup>-26</sup>
DEW POINT #2	-60 to +20 °C -76 to +68 °F 1 ° steps	-40 to +40 °C -8 to +104 °F 1 ° steps	-60 to +40 °C

PRE-REACTION OXYGEN #2	0 oxygen fixed	1 to 10.0% oxygen	0 to 4.0%
SENSOR EMF #1	0 to 1200 mV in 100 mV steps	100 to 1300 mV in 100 mV steps	0 to 1300mV
SENSOR EMF #2	0 to 1200 mV in 100 mV steps	100 to 1300 mV in 100 mV steps	0 to 1300mV
AUX TEMPERATURE	0 to 100 °C in 100 ° C steps	100 to 1400 °C in 100 ° C steps	0 to 1300°C

#### NOTE

1: Note that the reducing oxygen span is shown on the display as the exponent only. -1 represents  $10^{-1}$  % oxygen.

### 32. Centigrade/Fahrenheit Selection

Select whether displays and outputs are to be in ° Celsius or Fahrenheit

#### Options:

1. Celsius (Centigrade) \*
2. Fahrenheit

### 33. Lower Line Display Functions

In the run mode the upper line on the LCD display will always read % oxygen. The lower line can be set to read one or more of the following. Select as many as are required to be displayed by pressing the 'ENTER' button. Those selected will have an asterisk displayed alongside.

#### Options:

1. Probe 2 oxygen \*\*
2. Probe 1 and 2 oxygen averaged \*\*
3. Sensor 1 EMF
4. Sensor 2 EMF \*\*
5. Probe 1 temperature
6. Probe 2 temperature, Auxiliary temperature ( this will depend if one or two sensors are selected in set-up 1 )
7. Sensor 1 impedance
8. Sensor 2 impedance \*\*
9. Ambient temperature
10. Relative humidity
11. Dew point probe 1
12. Dew point probe 2 \*\*
13. Pre-reactive oxygen probe 1
14. Pre-reactive oxygen probe 2 \*\*
15. Dew point probe 1 and 2 averaged \*\*
16. Date and time
17. Run hours since last service
18. Date of last service

\*\* This will not appear if only one sensor is selected in set-up 1

If no lower line options are required then do not enter any. If options already selected are required to be deleted, select the required option and press the 'ENTER' button. The asterisk will be removed.

### 34. Flue Pressure

Enter flue pressure units, eg. 3 mm W.G.

#### Options:

- mm W.G. \*
- Kilopascals
- Inches W.G.

### 35. Flue Pressure Value

Enter flue pressure e.g. 3 mm WG. The default setting is 0

#### Limits :

-200 to +200 mm W.G.

-9 to +9 inches W.G.  
-200 to +200 kpa.

### 36. Purge / Cal Time

Set the first purge to occur at the correct time-of-day. If purging is not required but on-line auto gas calibration check is required, enter a time-of-day value suitable for the auto calibration checks. Cal Gas 1 will be tested ten minutes after the purge/cal time and Cal Gas 2, 20 minutes after. If neither purge nor auto calibration check is required, ignore this time setting.

**Range:**

0 to 23 hours in one hour steps. The default time is 12 noon.

### 37. Automatic Purge

For some oil and coal fired plant, probe filters are necessary and should be back-purged with sufficient frequency to avoid blocked filters. The outputs will be frozen during purging. If no purge is required, set-up steps 38, 39 and 40 will be skipped.

**Options:**

Yes

No \*

### 38. Time Between Purges

Set the time between purges eg. a two hourly purge or a 100 hourly purge.

**Range:**

1 to 199 hours. Default setting is 24 hours.

### 39. Purge Duration

Set up purge duration to a number between three and ten seconds. The filter is actually purged in less than one second, but three seconds are required for the purge flow switch to check that the filter is not blocked.

**Range:**

0 to 10 seconds. Default setting is 10 seconds.

### 40. Purge Freeze Time

After the purge period the transmitter output will remain fixed (frozen) for an adjustable period to allow the probe reading to return to the correct process level and avoid output 'bumps'. The freeze period time required will depend on the probe response time and thus its design, and whether it has a filter or not.

To determine the required freeze time, manually perform a purge while the plant is in operation and note the time required for the reading to return to the correct process level within approximately 0.5 % oxygen.

**Range:**

100 to 1000 seconds in ten second steps. Default setting is 60 seconds.

### 41. Number of Cal Gases

Select the number of cal gases 0, 1 or 2. For example, one may be air (20.9 % oxygen) and the other 2 % oxygen

**Options:**

No Cal Gases \*

Single Gas

Two Cal Gas

During the timed calibration check periods the transmitter outputs will be frozen and the analyser will alarm if readings are not within the accuracy limits sets in set-up steps 43 and 44. If autocal is not required enter 'NO CAL GAS' and the transmitter will step to set-up 54.

### 42. Oxygen Content of Cal Gas 1

Enter value of Cal Gas 1 (to one decimal point).

**Range:**

0.1 to 20.9 % oxygen. Default setting is 8.0 % oxygen.

### 43. Maximum Acceptable Positive Error Gas 1

Set the maximum positive error above which the 'Gas 1 Cal Error' alarm will be initiated after the timed period set in set-up step 47.

**Range:**

0.1 to 3.0 % oxygen. The default setting is 0.5 % oxygen.

#### **44. Maximum Acceptable Negative Error Gas 1**

Set the maximum negative error below which the 'Gas 1 Cal Error' alarm will be initiated after the timed period set in set-up step 47.

**Range:**

0.1 to 3.0 % oxygen. The default setting is 0.2 % oxygen.

#### **45. Period Between Gas 1 Autocal**

Set the number of hours between autocal Gas 1. A typical time would be 24 or 168 hours. (Daily or weekly).

**Range:**

1 to 1999 hours. The default setting is 1 hour.

#### **46. Duration Of Autocal Gas 1**

Set the number of seconds that the autocal gas solenoid will be open. At the end of this period, if the oxygen level measured is not within the limits set for Cal Gas 2, an 'Gas 2 Cal Error' will initiate. To determine the minimum time required for a particular length or design of probe to settle, manually admit cal gas while observing the oxygen reading in 'RUN' mode. Typical minimum times vary from 15 seconds to 90 seconds, depending on the probe length and gas plumbing arrangement. If there is a filter fitted to the oxygen probe, the calibration check reading will be much closer to the actual gas value.

**Range:**

0 to 90 seconds. The default setting is 10 seconds.

#### **47. Freeze Time Gas 1**

After the Cal Gas 1 period, the transmitter output will remain fixed (frozen) for an adjustable period to allow the probe reading to return to the correct process level and avoid output 'bumps'. The freeze period time required will depend on the probe response time, and whether or not it has a filter fitted.

**Range:**

10 to 100 seconds in ten second steps. The default setting is 30 seconds. To determine the required freeze time, manually perform a calibration check with Gas 1 while the plant is in operation and note the time required for the reading to return to the correct process level within approximately 0.5 % oxygen.

#### **48 to 53. Cal Gas 2 Parameters**

Enter the same requirements for Cal Gas 2 as per set-up steps 42 to 47 for Cal Gas 1. Cal Gas 2 could typically be 2 % oxygen in nitrogen.

#### **54. Process Alarm Enable**

If process alarms are not required, 'NO' can be selected. There will not be any process related alarms generated, and all process alarms will be cancelled, if 'NO' is selected.

The process alarms are High dew point, High dew point deviation, High pre-reaction oxygen, High oxygen, Low oxygen, Oxygen deviation, and Very low oxygen.

**Options:**

Yes

No \*

#### **55. High Oxygen Alarm #1**

Set the operating point for the high oxygen alarm relay. This alarm monitors the oxygen level from probe 1.

The alarm level is set as an exponent value.

ie. If the alarm level is set to -18, an alarm will be initiated (after the time set in set-up 56) if the oxygen measured by probe 1 is  $1.0^{-18}$  % or higher.

This menu item will only appear if Dew point is selected in set-up 85.

**Range:**

-10 to -25. The default setting is -18.

#### **56. High Oxygen Delay #1**

Typically set at 10 seconds. This delay is to avoid nuisance alarms when the furnace is undergoing transitions in firing rate or gas changes which can cause it to deviate from the oxygen set point, but recover quickly.

This menu item will only appear if Dew point is selected in set-up 85.

**Range:**

0–999 seconds. The default setting is 10 seconds.

### 57. High Oxygen Alarm #2

Set the operating point for the high oxygen alarm relay. This alarm monitors the oxygen level from probe 2. The alarm level is set as an exponent value.

ie. If the alarm level is set to -18, an alarm will be initiated (after the time set in set-up 58) if the oxygen measured by probe 1 is  $1.0^{-18}$  % or higher.

This menu item will only appear if Dew point is selected in set-up 85.

**Range:**

-10 to -25. The default setting is -18.

### 58. High Oxygen Delay #2

Typically set at 10 seconds. This delay is to avoid nuisance alarms when the furnace is undergoing transitions in firing rate or gas changes which can cause it to deviate from the oxygen set point, but recover quickly.

This menu item will only appear if Dew point is selected in set-up 85.

**Range:**

0–999 seconds. The default setting is 10 seconds.

### 59. High Dew Point #1

Set the operating point for the high dew point alarm relay. This alarm monitors the dew point level from probe 1.

This menu item will only appear if Dew point is selected in set-up 85.

The alarm level is set in degrees Centigrade.

**Range:**

-60 to -40. The default setting is -15.

### 60. High Dew Point Delay #1

Typically set at 10 seconds. This delay is to avoid nuisance alarms when the furnace is undergoing transitions in firing rate or gas changes which can cause it to deviate from the dew point set point, but recover quickly.

This menu item will only appear if Dew point is selected in set-up 85.

**Range:**

0–999 seconds. The default setting is 10 seconds.

### 61. High Dew Point #2

Set the operating point for the high dew point alarm relay. This alarm monitors the dew point level from probe 2.

The alarm level is set in degrees Centigrade.

This menu item will only appear if Dew point is selected in set-up 85.

**Range:**

-60 to -40. The default setting is -15.

### 62. High Dew Point Delay #2

Typically set at 10 seconds. This delay is to avoid nuisance alarms when the furnace is undergoing transitions in firing rate or gas changes which can cause it to deviate from the dew point set point, but recover quickly.

This menu item will only appear if Dew point is selected in set-up 85.

**Range:**

0–999 seconds. The default setting is 10 seconds.

### 63. High Dew Point Deviation

Set the operating point for the high dew point deviation alarm relay. This alarm monitors the dew point difference between probe 1 and probe 2.

The alarm level is set in degrees Centigrade.

This menu item will only appear if Dew point is selected in set-up 85.

**Range:**

-60 to -40. The default setting is 5.

### 64. High Dew Point Deviation Delay

Typically set at 10 seconds. This delay is to avoid nuisance alarms when there are short term deviations in the atmosphere at the two probes.

This menu item will only appear if Dew point is selected in set-up 85.

**Range:**

0–999 seconds. The default setting is 10 seconds.

## 65. High Oxygen Deviation

Set the operating point for the high dew point alarm relay. This alarm monitors the dew point level from probe 2. The alarm level is set in decades of oxygen %. ie. If the alarm level is set to 2, the oxygen of one probe would have to be 100 times or 2 decades higher than the other.

This menu item will only appear if Dew point is selected in set-up 85.

**Range:**

1-25 % oxygen decades. The default setting is 2.

## 66. High Oxygen Deviation Delay

Typically set at 10 seconds. This delay is to avoid nuisance alarms when the furnace is undergoing transitions in firing rate or gas changes which can cause it to deviate from the dew point set point, but recover quickly.

This menu item will only appear if Dew point is selected in set-up 85.

**Range:**

0–999 seconds. The default setting is 10 seconds.

## 67. High Pre-reaction Oxygen #1 Warning

Set the operating point for the high pre-reaction oxygen warning alarm relay. This alarm monitors the pre-reaction oxygen level from probe 1. This alarm could be used to give an early warning that the oxygen is rising in the appliance. Perhaps corrective action could be taken when this alarm is activated. If the oxygen continues to rise and reaches the alarm level set in the next menu item a higher level of control should be acted on. ie. The operator should start the shutdown sequence.

The alarm level is set in %.

This menu item will only appear if Pre-reaction is selected in set-up 85.

**Range:**

0.01 to 5.00. The default setting is 1.00.

## 68. High Pre-reaction Oxygen #1 Alarm

If the pre-reaction reaches this alarm level it is recommended that the shutdown sequence is started for the appliance. The alarm level is set in %.

This menu item will only appear if Pre-reaction is selected in set-up 85.

**Range:**

0.01 to 5.00. The default setting is 2.50.

## 69. High Pre-reaction Oxygen #2 Warning

Set the operating point for the high pre-reaction oxygen warning alarm relay. This alarm monitors the pre-reaction oxygen level from probe 2 in the same way that set-up 67 monitors the pre-reaction oxygen level from probe 1.

The alarm level is set in %.

This menu item will only appear if Pre-reaction is selected in set-up 85.

**Range:**

0.01 to 5.00. The default setting is 1.00.

## 70. High Pre-reaction Oxygen #2 Alarm

This alarm monitors the pre-reaction oxygen level from probe 2 in the same way that set-up 69 monitors the pre-reaction oxygen level from probe 1.

The alarm level is set in %.

This menu item will only appear if Pre-reaction is selected in set-up 85.

**Range:**

0.01 to 5.00. The default setting is 2.50.

## 71. Alarm Relay #2

Any or all of the following alarm functions may be used to activate the alarm relay. They may be selected or de-selected using the 'ENTER' buttons as in set-up step 33.

**Options :**

1. Dew point 1 high
2. Dew point 2 high
3. Oxygen 1 high
4. Oxygen 2 high

5. Oxygen deviation
6. Heater SSR Fail
7. Dew point deviation
8. Probe temperature
9. Gas calibration in progress
10. Purging probe in progress

### 72. Alarm Relay #3

Alarm relay #3 has the same functions available as alarm relay #2. See SET-UP 71.

### 73. Alarm Relay #4

Alarm relay #4 has the same functions available as alarm relay #2. See SET-UP 71.

In addition an alarm horn function is also available.

If 'Horn' is selected it will override any other selections. A relay selected as a 'Horn' driver will have the relay contacts open circuit if there is an un-accepted alarm, and closed when a new alarm occurs.

### 74. Data to Print

Any or all of the following values may be printed on a printer or computer connected to port 2. They may be selected or de-selected using the 'ENTER' buttons as in set-up step 33. The log period follows in set-up step 75. A sample of a print-out is contained in Appendix 3. RS to 232C protocol is :

Data word length	Eight bits
Stop bits	One
Parity	None

Oxygen from probe 1 is always printed, plus any of the following

#### Options :

1. Probe 2 oxygen \*\*
2. Probe 1 and 2 oxygen averaged \*\*
3. Sensor 1 EMF
4. Sensor 2 EMF \*\*
5. Sensor 1 temperature
6. Sensor 2 temperature, Auxiliary temperature ( this will depend if one or two sensors are selected in set-up 1 )
7. Sensor 1 impedance
8. Sensor 2 impedance \*\*
9. Ambient temperature
10. Relative humidity
11. Dew point probe 1
12. Dew point probe 2 \*\*
13. Dew point probe 1 and 2 averaged \*\*
14. Date to time
15. Run hours since last service
16. Date of last service

\*\* This will not appear if only one sensor is selected in set-up 1

### 75. Print Log Period

Select the time interval between data print outs on the printer.

#### Range:

1 to 2000 minutes

### 76. Printer Baud Rate

Select the correct BAUD rate for data to be transmitted out of the port to the printer.

#### Options:

1200  
2400  
4800  
9600 \*

## 77. Reference Air Selection

The reference air supply for the oxygen sensor is normally supplied from the analyser. If the internal pump is not being used, 'External' must be selected to stop the 'Ref Pump Fail' alarm. If an external air supply that has a known relative humidity, select 'Instrument Air'. This will allow the relative humidity level to be entered in set-up 78.

Less than half a litre per minute provides sufficient reference air for any sensor.

**Note:** If 'Internal' is selected, and a reference airflow sensor is connected to CN8 on the 1630-2 (terminal) PCB, the pump is cycled on and off within a minute.

### Options:

Internal \*  
External  
Instrument air

## 78. Reference Air Relative Humidity

This selection will only appear if 'Instrument Air' is selected in set-up 73.

If the reference air is being supplied from an instrument air supply, the relative humidity will be different from the ambient air being measured within the analyser. In this case set the RH to the RH of the air supply. As a guide, the RH of a compressor driven air supply is up to 10%.

### Range:

1-100%

## 79. Damping Factor

Each time a new reading is read from the oxygen probe or sensor, the new reading is averaged with the last readings taken, before the new average is either displayed on the LCD, or sent to the 4 to 20 mA output. The smoothing of the oxygen signal is an exponential function. If a factor of 5 is used, a step change of input signal will take about 5 seconds to reach 63% of the change on the output/display. A value of zero entered here will mean that every new reading from the probe or sensor will be sent to the display unaltered.

### Range

0 to 20. Default setting is 5. Zero will turn the damping off.

## 80. Digital Output Filter Enable

If the dew point reading on the display or on the 4-20 output reads short duration unexpected changes, the digital filter may be enabled to exclude these nuisance diversions.

### Options

Yes  
No \*

## 81. External Hydrogen Level Input Enable

If the hydrogen level in the furnace varies by more than 15% of the hydrogen value, automatic on line compensation can be made by feeding the hydrogen level into the 1638 analyser. The signal must be proportional to hydrogen, but can represent any range (zero and span ) from 0 to 100%.

The signal can either be a 0 to 5 volt or a 0 to 20 mA level.

Normally the hydrogen in the furnace is constant, and therefore select 'No' in this function, and set a hydrogen level in set-up 84.

### Options

Yes  
No \*

## 82. External Hydrogen Level Input Zero Level

Set the zero level of your hydrogen level signal.

If your signal is proportional to hydrogen from 5 to 20 %, set this function to 5 %.

### Range

0 to 100 Default setting is 0 %

## 83. External Hydrogen Level Input Span Level

Set the span level of your hydrogen level signal.

If your signal is proportional to hydrogen from 5 to 20 %, set this function to 20 %.

**Range**

0 to 100 Default setting is 100 %

### 84. Fixed Hydrogen Level

Set the hydrogen of the furnace to be used in the calculation of dew point. This is not required if an external hydrogen input is being used (set-up steps 82 and 83)

**Range**

0.0 to 100.0 Default setting is 6.5 %

### 85. Pre-reaction Oxygen or Dew Point Instrument Mode Selection

The 1638 has been designed to measure oxygen in a hydrogen/nitrogen atmosphere. However, to simplify the operation of the instrument, the 4-20mA output ranges, the alarms and the lower line displays will be tailored to suit the selected instrument mode.

**Options**

Dew Point \*

Pre-reaction Oxygen

**Range**

0 to 100 Default setting is 100 %

### 86. MODBUS™ Address

This function is used when networking of one or more analyser back to a master computer or data acquisition system is required. For more details on the functions of the MODBUS™ see Section 2.12, and Appendix 6.

The valid range of MODBUS™ addresses is from 1 to 31. Any analyser with zero selected as the MODBUS™ address will have the MODBUS™ disabled, and the data log function enabled.

For the connection details, see Section 3.15.

**NOTE:** If the MODBUS™ address is changed, the analyser must be turned off and back on for the address change to take effect.

**Range:**

0-31 Default setting is 0 which disables the MODBUS communications.

# MAINTENANCE

# 6

SECTION  
NUMBER

**TRANSMITTER MAINTENANCE**

- 6.1 COLD START
- 6.2 A/D CALIBRATION
- 6.3 D/A CALIBRATION
- 6.4 PUMP REPLACEMENT
- 6.5 BACK TO UP BATTERY REPLACEMENT
- 6.6 ELECTRONIC REPAIRS

**PROBE & SENSOR MAINTENANCE**

- 6.7 INSTALLING A NEW PROBE OR SENSOR
- 6.9 TEST EQUIPMENT REQUIRED
- 6.10 TESTING A PROBE OR SENSOR
- 6.11 PROBE OR SENSOR THERMOCOUPLE
- 6.12 HEATER FAILURE
- 6.13 FILTER BLOCKAGE

## TRANSMITTER MAINTENANCE

### 6.1 Cold Start

A 'COLD START' will reset all 'Set-up' mode entries to their normal default values. 'COLD START' will show on the display for a second prior to a microprocessor initialising sequence, which takes about seven seconds.

After a 'COLD START', it is necessary to set all new variables in the 'SET-UP' mode, including calibration voltages and time and date.

#### To initiate a 'COLD START' -

Turn the mains power off

Remove the 'COLD START LINK' (this is located on the door PCB, next to the keyboard lock switch, behind the shield)

Turn the mains power on. The message "Cold Start....." will be displayed.

Leave the LINK off until the message "Replace c/s Link" is displayed. Replace the LINK.

The date and version number of the software will be displayed.

A 'WARM START', which is performed by applying power with the COLD START LINK in its place, will retain all data previously entered in the Set-up mode.

### 6.2 A/D Calibration

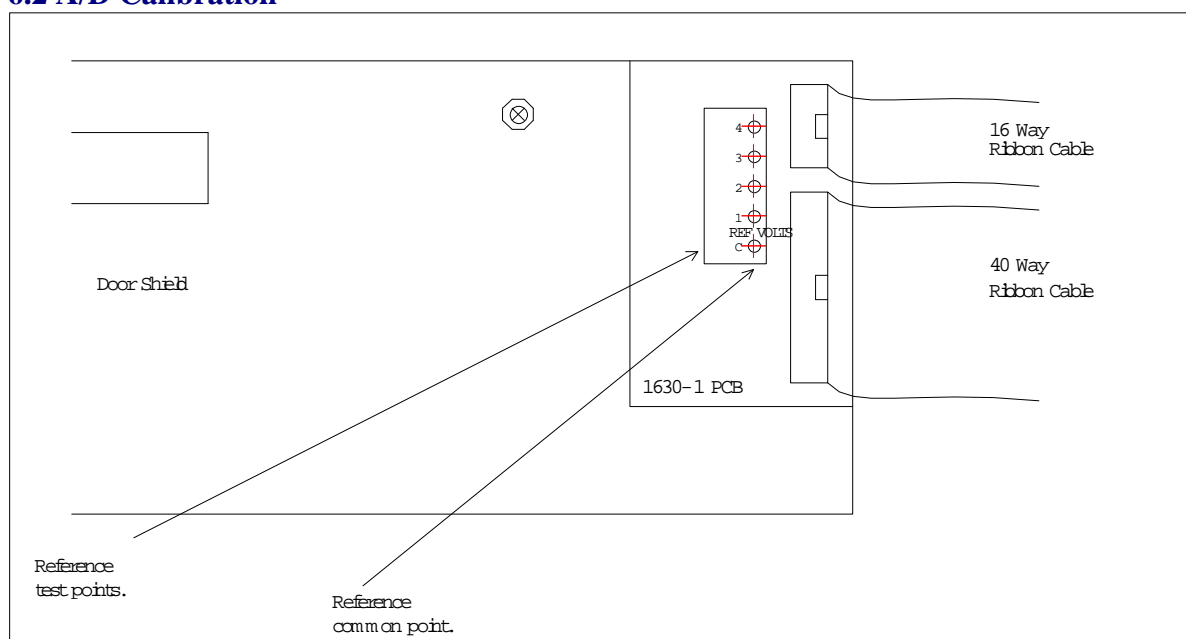

**Location of Calibration Test Points**

The analyser maintains its accuracy over a very long by continuously checking itself against internal stabilised references. The only calibration required is to set the actual values of these references into battery backed memory. The analyser will read these references every minute and update its zero and span correction factors. See Section 5.5.7 to 10. These references should be checked every 12 months. An AUTOCAL of the analog output section should always be performed if these references are altered. See Section 6.3.

### 6.3 D/A (4-20mA output channels) Calibration

The calibration can either be done using the 'Auto Cal' or 'Manual Cal'.

#### *Auto Cal*

The 'Auto Cal' mode is selected in set-up 13 (and 16 for channel 2).

The analyser will automatically divert the output back to the input, measure the offset and span, and record the calibration factors for each channel.

If either of the channels are selected to be calibrated manually, the factors will not be changed by an 'Auto Cal'.

#### *Manual Cal*

The 'Manual Cal' mode is selected in set-up 13 (and 16).

Set the 4mA calibration first and then the 20mA calibration.

1. Select 'Set 4mA Trim' in set-up 13 (or 16).

2. Return to RUN mode.
3. Measure the output on the channel to be calibrated with a digital multimeter. If the current is not exactly 4.00mA, return to set-up mode and change the 4mA calibration factor in set-up 14 (or 17).
4. Re-measure the current while back in RUN mode until the current is within 3.9 to 4.1mA.
5. Return to set-up mode and select 'Manual Cal' in set-up 13 (or 16).

Set the 20mA calibration factor.

6. Select 'Set 20mA Trim' in set-up 13 (or 16).
7. Return to RUN mode.
8. Measure the output on the channel to be calibrated with a digital multimeter. If the current is not exactly 20.00mA, return to set-up mode and change the 20mA calibration factor in set-up 15 (or 18).
9. Re-measure the current while back in RUN mode until the current is within 19.9 to 20.1mA.
10. Return to set-up mode and select 'Manual Cal' in set-up 13 (or 16).

This calibration is now saved in battery backed memory until

The factors are changed in the manual calibration

The analyser is forced into a COLD-START (see section 6.1)

The calibration mode in set-up 13 (or 16) is changed to Auto Cal and an Auto Cal is initiated.

**NOTE:** The 4mA or the 20mA trim mode will only be held on the output channels for 30 minutes before automatically returning to 'Manual Cal' mode in set-up 13 (or 16).

## 6.4 Pump Replacement

The reference air pump is mounted on the 1630-2 PCB in the base of the analyser. The operation of the pump is monitored by the analyser and alarms will be shown if a fault occurs. ("Pump Fail" alarm, "Pump Blocked" alarm)

To replace the pump, unplug all the field wiring terminals. ie. Probe connectors, power connector etc.

Unplug the 10 way and the 40 way ribbon connectors. Remove the 5 captive screws that retain the terminal PCB in the base of the case. Remove the PCB from the case. The pump can now be un-screwed, and the wires un-plugged.

## 6.5 Back-Up Battery Replacement

The back-up battery is contained within the battery-like real time clock/memory module, plugged into socket M2. It is rated for an average service life of greater than ten years. The module is not re-chargeable and should be replaced every three years with a stored transmitters with power off or every eight years with a transmitters which have had the power on. The memory module must be purchased from Novatech Controls or an agent of Novatech Controls.

After replacing the battery, re-enter all set-up mode functions.

## 6.6 Electronic Repairs

Electronic schematics are included in Appendix 4. A competent electronic technician could perform troubleshooting with these schematics, aided by the analyser self-diagnostic alarms. It is recommended that service be performed on a change-over circuit board basis. A fast turn-around or replacement service is available from Novatech or accredited service agents. Other service aids, including a test EPROM firmware package and probe input simulator are also available.

## 6.7 Installing A New Probe Or Sensor

Whenever a new oxygen probe or sensor is installed, the millivolt offset value should be entered. To achieve this refer to set-up 11 (and 12 for the second sensor).

The probe or sensor offset is noted on a tag or label attached to probe or sensor. To check an offset on site, the probe must be sensing air with reference air connected and allowed to settle at the operating temperature for 10 minutes. Read the offset in 'RUN' mode in millivolts on the lower line. Offset errors can occur if the sensor does not have some air passing over it. A gentle flow of air in the calibration check port can be provided by a reference air pump or similar. If a probe is in a process with the process running, the air purge on the sensing side of the sensor will only be successful if the probe has a filter or small sensing hole. Probes with open sensing ends or with large sensing holes allow the process gas to mix with the calibration gas, giving a false reading.

For heated probes or sensors, if the combustion appliance is not operational and the probe or sensor heater is interlocked with the 'FUEL ON' signal, the 'BURNER BYPASS' switch should be set to 'BYPASS' to power the probe or sensor heater after removing the probe from the flue. For unheated probes, the sensing tip must be raised to at least 650°C with a portable furnace.

## CAUTION DANGER

**Return the 'BURNER BYPASS' switch to normal (off) before installing the probe in the flue.**

### 6.8 Test Equipment Required

All measurements are simplified if an analyser is connected to the probe or sensor. Readings can then be easily taken of sensor impedance, EMF, temperature and percent oxygen. The analyser also provides proper heater control for heated probes or sensors.

The following tests are described using readily available workshop equipment where an analyser is not available. If an analyser is available the same test procedures will apply. First check all alarms on the analyser, allowing time for the probe or sensor to heat up after switch on.

An instrument to measure sensor EMF and temperature is required. A 3 1/2 or 4 1/2 digit multimeter will perform both measurements.

A separate temperature indicator to suit the probe or sensor thermocouple type is also useful, although not necessary.

A reference air pump is required and a cylinder of calibration check gas e.g. 2 % oxygen in nitrogen. The cylinder should have a pressure and flow regulator. Both of these are inexpensive devices available from gas supply companies. The calibration check gas should be chromatograph tested to an accuracy of 0.1 % oxygen.

### TEST EQUIPMENT FOR UNHEATED PROBES

A small test furnace capable of raising the probe tip temperature to 720 °C is required. The furnace should have a uniform temperature for about 50 mm either side of the sensor tip.

### TEST EQUIPMENT FOR HEATED PROBES OR SENSORS

If a 1638 analyser is available at the test location then no other equipment will be required. If not, then a controllable power source for the heater is required. A Variac (variable transformer), set to approximately 100 or 240 volts will regulate the sensor temperature to 720° C.

### 6.9 Testing a Probe or Sensor

With the sensor heated to approximately 720 °C, either from a small test furnace or its own internal heater, connect a digital multimeter to the sensor electrode conductors. Connect the multimeter positive to the internal electrode conductor. Connect reference air to and apply a gentle purge of air to the probe calibration check port. Reference air flow should be the smallest flow available (less than 50 cc per minute). The multimeter should read zero millivolts  $\pm$  two millivolts. If not, then there is a problem with the probe electrodes and the sensor needs refurbishing. Normally a faulty probe electrode is indicated with a high source impedance. 1234 sensors do not require reference air but a gentle flow of air should be admitted into the sample connection.

To test the source impedance, set the multimeter to read ohms and take a measurement within a couple of seconds, of the sensor impedance. Reverse the multimeter and repeat the reading. Take the average of the two readings for an approximate measurement of impedance. If the impedance is above 10k $\Omega$ , then the probe or sensor needs to be replaced. The sensor must be 720°C or above for this measurement. The reason that impedance measurements need to be performed quickly, is that the zirconia sensor polarises with the DC voltage from the multimeter across it.

If the probe or sensor tests reveal less than 2 mV offset and a good impedance reading, the next step is to apply a calibration check gas. The calibration check gas should be inserted in the calibration check port. With the calibration check gas flowing, the sensor should develop an EMF according to the tables in Appendix 1. If the EMF reading is low then there may be insufficient calibration check gas flow. Increase the calibration check gas until the reading is correct. An excessive calibration check gas flow will cause cooling on one surface of the sensor, giving temperature differential errors on the sensor.

As an alternative, using the reference air port, the calibration check gas can be inserted into the inside of a probe sensor. This requires a lower flow rate, and thus lower usage of calibration check gas. The flow rate should be similar to that of the reference air, which should be removed for internal calibration check. The sensor EMF reading will be identical but negative in polarity. A small flow of air should be flowing over the outside of the sensor, when testing in this way.

Occasionally, a sensor can develop offset with a polluted electrode caused by contaminants in the flue gas stream. In this case the impedance may be OK but the output incorrect. This phenomena is rare.

### **6.10 Probe or Sensor Thermocouple**

Although some unheated probes are specified without a thermocouple, most probes, both heated and unheated, have an integral thermocouple which is fitted in to the four bore insulator. The analyser has an alarm function which will advise the operator of an open circuit thermocouple, however bench testing can be performed by simply measuring the thermocouple continuity.

### **6.11 Heater Failure**

For heated probe or sensors, a heater failure will cause a 'PROBE TEMPERATE' or 'HEATER FAIL' alarm. Heaters can be tested with a continuity test. The heater impedance should be approximately 100Ω. Should the heater be open or short circuited, replace the probe or sensor.

### **6.12 Filter Blockage**

For oxygen probes or flow guide tubes with filters in installations with entrained solids in the flue gas, it is sometimes necessary to replace the filter. Filters are normally cleared with back purging. However fine fly-ash, or other particles can ultimately completely block a filter necessitating filter replacement. A new probe filter can be fitted



# APPENDICES

1. **Constituent Values for Various Fuels**
2. **Probe EMF Tables**
3. **% OXYGEN SCALE to LOGARITHMIC**
4. **Sample Log Print Out**
5. **Circuit SchematicS**



# APPENDIX 1

## SENSOR EMF TABLES

# ZIRCONIA OXYGEN SENSOR OUTPUT (mV) PROBE TYPE 1231, SENSOR TYPE 1234

**% OXYGEN      mV at 720° C**

---

21.0	0.00
20.5	0.46
20.0	0.99
19.5	1.53
19.0	2.09
18.5	2.66
18.0	3.25
17.5	3.85
17.0	4.47
16.5	5.11
16.0	5.77
15.5	6.45
15.0	7.15
14.5	7.87
14.0	8.62
13.5	9.40
13.0	10.21
12.5	11.05
12.0	11.92
11.5	12.83
11.0	13.78
10.5	14.78
10.0	15.82
9.5	16.92
9.0	18.08
8.5	19.30
8.0	20.60
7.5	21.98
7.0	23.45
6.5	25.04
6.0	26.75
5.5	28.61
5.0	30.65
4.5	32.90
4.0	35.42
3.5	38.28
3.0	41.58
2.5	45.48
2.0	50.25
1.5	56.41
1.0	65.08
0.5	79.91
0.2	99.51

---

**'K' TC mV      29.212 at 720°C**

These tables are based on the Nernst equation:

Sensor e.m.f. =  $0.02154 \times T \times \ln \times 20.95 / \% \text{ oxygen}$ , where  $T = ^\circ \text{K} (^{\circ} \text{C} + 273)$ , e.m.f. is in mV's

## ZIRCONIA OXYGEN PROBE OUTPUT (mV) PROBE TYPE 1232

% O <sub>2</sub>	TEMPERATURE (°C)								
	600	700	800	900	1000	1100	1200	1300	1400
20	0.917	1.023	1.128	1.233	1.338	1.443	1.548	1.653	1.758
19.5	1.394	1.553	1.713	1.872	2.032	2.192	2.351	2.511	2.671
19	1.882	2.098	2.313	2.529	2.744	2.960	3.175	3.391	3.607
18.5	2.383	2.657	2.930	3.203	3.476	3.749	4.022	4.295	4.568
18	2.899	3.231	3.563	3.895	4.227	4.559	4.891	5.223	5.555
17.5	3.428	3.821	4.214	4.607	4.999	5.392	5.795	6.177	6.570
17	3.974	4.429	4.884	5.339	5.794	6.249	6.705	7.160	7.615
16.5	4.535	5.054	5.574	6.093	6.613	7.132	7.652	8.171	8.691
16	5.114	5.699	6.285	6.871	7.457	8.042	8.628	9.214	9.800
15.5	5.711	6.365	7.019	7.673	8.327	8.981	9.635	10.289	10.944
15	6.327	7.052	7.777	8.501	9.226	9.951	10.676	11.400	12.125
14.5	6.965	7.762	8.560	9.358	10.156	10.954	11.751	12.549	13.347
14	7.625	8.498	9.371	10.245	11.118	11.991	12.865	13.738	14.612
13.5	8.308	9.260	10.212	11.164	12.115	13.067	14.019	14.970	15.922
13	9.018	10.051	11.084	12.117	13.150	14.183	15.216	16.249	17.282
12.5	9.756	10.873	11.991	13.108	14.226	15.343	16.461	17.578	18.695
12	10.523	11.729	12.934	14.139	15.345	16.550	17.756	18.961	20.167
11.5	11.324	12.621	13.918	15.215	16.512	17.809	19.106	20.403	21.700
11	12.159	13.552	14.945	16.338	17.731	19.124	20.516	21.909	23.302
10.5	13.034	14.527	16.020	17.513	19.006	20.499	21.992	23.486	24.979
10	13.952	15.550	17.148	18.746	20.344	21.942	23.540	25.139	26.737
9.5	14.916	16.625	18.333	20.042	21.751	23.459	25.168	26.877	28.585
9	15.933	17.758	19.583	21.408	23.233	25.058	26.883	28.709	30.534
8.5	17.008	18.956	20.904	22.852	24.801	26.749	28.697	30.645	32.593
8	18.148	20.227	22.305	24.384	26.463	28.542	30.620	32.669	34.778
7.5	19.361	21.579	23.797	26.015	28.223	30.450	32.668	34.886	37.104
7	20.659	23.025	25.392	27.758	30.124	32.491	34.857	37.224	39.590
6.5	22.052	24.578	27.104	29.630	32.156	34.683	37.209	39.735	42.261
6	23.557	26.256	28.954	31.653	34.351	37.050	39.748	42.447	45.145
5.5	25.194	28.080	30.965	33.851	36.737	39.623	42.509	45.395	48.281
5	26.986	30.077	33.168	36.259	39.351	42.442	45.533	48.624	51.715
4.5	28.967	32.285	35.603	38.922	42.240	45.558	48.876	52.194	55.512
4	31.182	34.754	38.326	41.897	45.469	49.041	52.613	56.185	59.757
3.5	33.693	37.552	41.412	45.271	49.131	52.990	56.850	60.709	64.569
3	36.592	40.783	44.975	49.166	53.358	57.549	61.741	65.932	70.124
2.5	40.020	44.604	49.189	53.773	58.357	62.941	67.525	72.110	76.694
2	44.216	49.281	54.346	59.411	64.476	69.541	74.605	79.670	84.735
1.5	49.626	55.310	60.995	66.680	72.364	78.049	83.733	89.418	95.102
1	57.250	63.808	70.366	76.924	83.482	90.040	96.598	103.156	109.714
0.5	70.285	78.336	86.387	94.438	102.488	110.539	118.590	126.641	134.692
0.2	87.515	97.540	107.564	117.589	127.614	137.638	147.663	157.687	167.712
<b>TC mV</b>									
'R'	5.582	6.741	7.949	9.203	10.503	11.846	13.224	14.624	16.035
'K'	24.902	29.128	33.277	37.325	41.269	45.108	48.828	to	to
'N'	20.609	24.526	28.456	32.370	36.248	40.076	43.836	47.502	to

These tables are based on the Nernst equation:  
 Probe emf = 0.02154 x T x ln x 21% oxygen  
 Where T = ° K (° C + 273)

## Dew Point Calculations at 720°C & 900°C

EMF from sensor	Hydrogen level 6.5 % Sensor temperature 720 °C		Hydrogen level 6.5 % Sensor temperature 900 °C	
	Oxygen %	Dew Point °C	Oxygen %	Dew Point °C
950	1.09E-18	43.29	9.91E-16	23.15
960	6.83E-19	39.30	6.67E-16	20.01
970	4.28E-19	35.34	4.49E-16	16.91
980	2.68E-19	31.42	3.03E-16	13.87
990	1.68E-19	27.57	2.04E-16	10.89
1000	1.05E-19	23.78	1.37E-16	7.96
1010	6.60E-20	20.06	9.23E-17	5.08
1020	4.14E-20	16.41	6.21E-17	2.25
1030	2.59E-20	12.83	4.18E-17	-0.37
1040	1.62E-20	9.33	2.82E-17	-2.73
1050	1.02E-20	5.91	1.90E-17	-5.05
1060	6.38E-21	2.56	1.28E-17	-7.34
1070	4.00E-21	-0.54	8.59E-18	-9.58
1080	2.51E-21	-3.32	5.79E-18	-11.80
1090	1.57E-21	-6.05	3.90E-18	-13.97
1100	9.84E-22	-8.72	2.62E-18	-16.11
1110	6.17E-22	-11.35	1.77E-18	-18.22
1120	3.86E-22	-13.92	1.19E-18	-20.29
1130	2.42E-22	-16.45	8.00E-19	-22.33
1140	1.52E-22	-18.92	5.39E-19	-24.33
1150	9.51E-23	-21.35	3.63E-19	-26.31
1160	5.96E-23	-23.74	2.44E-19	-28.25
1170	3.73E-23	-26.08	1.64E-19	-30.17
1180	2.34E-23	-28.38	1.11E-19	-32.05
1190	1.47E-23	-30.63	7.45E-20	-33.90
1200	9.19E-24	-32.85	5.01E-20	-35.73
1210	5.76E-24	-35.02	3.38E-20	-37.53
1220	3.61E-24	-37.16	2.27E-20	-39.30
1230	2.26E-24	-39.25	1.53E-20	-41.05
1240	1.42E-24	-41.31	1.03E-20	-42.77
1250	8.87E-25	-43.34	6.94E-21	-44.47
1260	5.56E-25	-45.33	4.67E-21	-46.14
1270	3.48E-25	-47.28	3.14E-21	-47.78
1280	2.18E-25	-49.21	2.12E-21	-49.40
1290	1.37E-25	-51.10	1.42E-21	-51.00
1300	8.58E-26	-52.95	9.59E-22	-52.58
1310	5.37E-26	-54.78	6.46E-22	-54.13
1320	3.37E-26	-56.58	4.35E-22	-55.67
1330	2.11E-26	-58.35	2.93E-22	-57.18
1340	1.32E-26	-60.09	1.97E-22	-58.67
1350	8.29E-27	-61.80	1.33E-22	-60.14
1360	5.19E-27	-63.48	8.93E-23	-61.59
1370	3.25E-27	-65.14	6.01E-23	-63.02
1380	2.04E-27	-66.77	4.05E-23	-64.43
1390	1.28E-27	-68.38	2.72E-23	-65.82
1400	8.01E-28	-69.96	1.83E-23	-67.20

# APPENDIX 2

## % OXYGEN SCALE to LOGARITHMIC

% OXYGEN	% FULL SCALE
0.1	0
0.15	7.66
0.2	13.1
0.3	20.7
0.4	26.2
0.6	33.8
0.8	39.2
1	43.5
1.5	51.1
2	56.5
3	64.2
4	69.6
6	77.3
8	82.7
10	86.9
12	90.8
14	93.3
16	95.8
18	98
20	100



# APPENDIX 3

## SAMPLE LOG PRINT OUT

Novatech Controls 04-07-1995 06:13:59  
Oxygen % 1.86  
EMF 1 mV 38.0  
Probe Temp 458C  
Ambient T 21.9C  
Servc'd 03/07/95  
Humidity 43%  
Sensor 1 Imp 5.7K  
Next Purge at 06:00:00 17-10-1995  
Next Print at 06:27:00 17-10-1995  
06:00:11 04-07-1995 Heater 1 Fail Is Active  
06:00:13 04-07-1995 O2% Low Is Active  
02:33:17 04-07-1995 RefPump Fail Accepted



CIRCUIT SCHEMATICS



































# APPENDIX 5

## MODBUS™ Register Map and Application Notes

MODBUS™ Functions Supported are:-

ReadHolding Register Function 3  
WriteHolding Register Function 6 ( for allowable addresses only )

### Introduction.

The 1638 Analyser implements the MODBUS™ slave protocol, it is intended to work in conjunction with a MODBUS™ master.

This is accomplished by setting the MODBUS™ address to some non-zero value in the range 1-31, setting the jumper positions to select the RS485 half duplex configuration, and re-starting the analyser.

The master must be configured as follows.

Baud Rate	9600
Parity	none
Stop Bits	1
RS485	Half Duplex
Mode	RTU ( binary mode)

A typical transaction would be to read the current value of a variable from the analyser.

The master send a ReadHoldingRegister packet, with the appropriate address and the analyser responds with data at that address.

The Register Addresses are as follows, to convert to Schneider addresses for earlier model PLC's address space, add 40001 to each address.

or for later model PLC's with linear address space the address corresponds directly to %MW XXXX address.

For Example, to read probe temperature setpoint -

Read %MW1436 which is equivalent to holding register  $41437 = 40001 + 1436$

Some data is 32 bit data (double) which requires some care to ensure that the word order is correctly interpreted.

For Example, OXYGEN32, (dual probe) which is at address 2052 is interpreted as follows.

2052 contains the high 16 bits for probe 1 oxygen

2053 contains the low 16 bits for probe 1 oxygen

2054 contains the high 16 bits for probe 2 oxygen

2055 contains the low 16 bits for probe 2 oxygen

## Configuration and Setup Addresses

### Holding

Reg.	Function	Description
716	Probe #1 offset	10 = 1.0mV
717	Probe #2 offset	10 = 1.0mV

### Purge and calibration-check gas control related variables

754	Purge enable	0= off, 1= on
749	Gas calibration check	0= off, 1= 1 gas, 2= 2 gasses

### Process measured and calculated variables

2048	Probe #1 OXYGEN	Floating point mantissa and exponent 1174 -2 = 11.74%
2050	Probe #2 OXYGEN	Floating point mantissa and exponent 1174 -5 = .01174%
2052	Dew point, °C	-2345 = -23.45 °C
2054	Dew point, °C	-2345 = -23.45 °C
2056	Probe #1 EMF	100,000 = 100.000 mV
2058	Probe #2 EMF	100,000 = 100.000 mV
2060	Probe #1 temperature	7000 = 700 °C
2062	Probe #2 temperature	7000 = 700 °C
2064	Probe #1, Impedance	1,000 = 1 k $\Omega$
2066	Probe #2, Impedance	1,000 = 1 k $\Omega$
2068	Oxygen average of 2 probes	Floating point mantissa and exponent 1174 -3 = 1.174%
2070	Dew Point average of 2 probes	-2345 = -23.45 °C
2072	Ambient temperature	246 = 24.6
2074	Ambient RH	561 = 56.1
2076	ALRM-ARRAY	Array of current alarm status. See below
2092	ALRM-TIMES	Array of timestamp of alarms

## Alarm array order -

1. Heater 1 fail
2. Sensor1 fail (Impedance too high)
3. Probe 1 filter blocked
4. Probe 1 thermocouple open circuit
5. Reference air Pump fail
6. Battery backed RAM fail
7. Mains frequency measurement fail
8. ADC warning (outside normal specifications, but still accurate)
9. DAC warning (outside normal specifications, but still accurate)
10. Dew Point 1 High
11. Dew Point 2 High
12. Oxygen % 1 High
13. Oxygen % 2 High
14. Heater SSR fail
15. Dew Point deviation too high between oxygen probes
16. Gas 1 calibration error
17. Gas 2 calibration error
18. Burner bypass switch on
19. Aux. thermocouple open circuit
20. ADC calibration fail
21. DAC Calibration fail
22. Probe Calibration
23. Heater 2 Fail
24. Sensor 2 Fail (Impedance too high)
25. Probe 2 thermocouple open circuit
26. Probe temperature below 650 °C
27. Gas calibration check in Progress
28. Probe Purging in progress
29. Alarm horn
30. Probe Temperature high

## 1638 Modbus Holding Registers for Alarms

The 1638 Modbus analyser has 30 alarm and warning states, all of which can be checked via Modbus. These 30 alarm and warning states cover all aspects of the operation of the analyser. For each of the 30 alarms, the 1638 has 5 possible states for each alarm:

- 0 Inactive
- 1 Timer Delay
- 2 Active
- 3 Accepted
- 4 Self Cleared

All alarm states are self explanatory except the timer delay state. In this state, the physical conditions required to trigger the alarm have already been met, but the alarms timed delay is preventing the alarm from being active. If the delay timer finishes counting down before the alarm state has been self cleared, the alarm will become active.

For checking alarms via Modbus, it is recommended to treat all alarms in a 'timer' state the same as inactive.

### 16-bit Byte Order Architecture

The 1638 Analyser uses 'big endian' byte architecture, meaning that for a 16-bit address block, the most significant byte (msb) appears first, followed by the least significant byte (lsb) second.

This becomes important for reading alarm states from the 1638 holding registers as all Modbus registers are treated as 16-bit variables. For the 1638 Modbus alarm holding registers, each 16-bit register contains two 8-bit alarm states, meaning that to check any single alarm state via Modbus will require 2 alarm states to be received, the second may be discarded.

This table shows the holding register and the relevant byte for each of the alarms states:

A#	Description	HR#	A#	Description	HR#
1	Heater 1 Fail	2076	16	Gas 1 Calibration Error	2083
2	Sensor 1 Fail	2076	17	Gas 2 Calibration Error	2084
3	Probe 1 Filter	2077	18	Burner Bypass	2084
4	Probe 1 TC Open	2077	19	AUX TC Open	2085
5	Reference Air Pump Fail	2078	20	ADC Calibration Fail	2085
6	Battery Backup Memory Fail	2078	21	DAC Calibration Fail	2086
7	Mains Power Fail	2079	22	Probe Calibration Fail	2086
8	ADC Warning	2079	23	Heater 2 Fail	2087
9	DAC Warning	2080	24	Sensor 2 Fail	2087
10	Dew Point 1 High	2080	25	Probe 2 TC Open	2088
11	Dew Point 2 High	2081	26	Probe Temp	2088
12	Oxygen 1 High	2081	27	Calibration in Progress	2089
13	Oxygen 2 High	2082	28	Probe Purge	2089
14	Heater SSR Fail	2082	29	Alarm Horn	2090
15	Dew Point Deviation	2083	30	Probe Temperature High	2090

For example, if you wished to read the state of the Heater SSR Fail Alarm, you would be looking for the msb from the holding register 2082. This would mean that for big endian byte order, you would be looking at the first byte in the analyser response if you requested a read single register from register 2082.

# Declaration of Conformity

**Application of Council Directives:**

89/336/EEC (92/31/EEC)  
72/23/EEC

**Standards to which conformity is declared:**

EN550011.1:1995 (ISM, Group 1, Class B)  
EN55014:1995 (Clause 4.2)  
EN50082-2 (Industrial)  
EN61010-1  
AS61000.4.5:1999  
IEC-68-2-2  
IEC-68-2-3  
AS1099.2.6

**Manufacturer's name:**

**Novatech Controls Pty Ltd**

**MANUFACTURER'S ADDRESS:**

309 RESERVE ROAD  
Cheltenham VIC 3192  
AUSTRALIA

**Type of equipment:  
Equipment Class:**

Oxygen Transmitter  
SM, Group 1, Class B

**MODEL NUMBER:**

1630 SERIES TRANSMITTER  
231 Oxygen Probe  
234 Oxygen Sensor

---

*I hereby declare that the equipment specified herein conforms to the above directive(s) and standards(s).*



Full Name: **Fraser Chapman**  
Position: **R & D Manager**

